



OPTIMUM 1930 E

Optimum compactness

- Width of 2 ft 6 in to operate in the most congested areas
- Compact stowed height for easy access through standard doorways

Exceptional productivity

- Driveable at full height
- Load capacity up to 500 lbs
- Extended platform
- Long working cycles

Reliable and easy to maintain



Haulotte 
GROUP
More than lifting



OPTIMUM 1930 E

ELECTRIC SCISSOR LIFTS

Optimum 1930 E

TECHNICAL DATA

Optimum 1930 E

Working height	24 ft 11 in
Platform height	18 ft 11 in
Driveable at full height up to	18 ft 11 in
Lift capacity - inside	500 lbs
Lift capacity - outside	N/A
A Platform length - outside	5 ft 8 in
B Platform length - extended	8 ft 8 in
Extension length	3 ft
C Platform width - outside	2 ft 3 in
D Storage height	6 ft 7 in
E Height - stowed	6 ft 7 in
F Overall width	2 ft 6 in
G Length	6 ft 2 in
H Wheelbase	4 ft 6 in
I Ground clearance	4 in
Ground clearance - Pothole guards deployed	1 in
Drive speed	0.4 - 2.8 mph
Gradeability	25 %
Lift / lower speed	20 s / 37 s
Turning radius - outside	5 ft 7 in
Non-marking tires	12.5 x 4.25
Batteries	24 V - 180 Amph (C5)
Hydraulic system capacity	5 gal
Weight	3,131 lbs

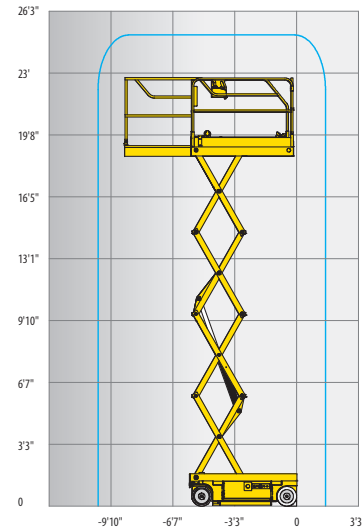

STANDARD EQUIPMENT

- Pothole guards
- Battery charge indicator
- Proportional lift and drive
- Slide out battery compartment
- Swing out component tray
- Battery charger 110V / 60Hz
- Non-marking tires
- Free wheeling device
- Tilt alarm
- Load management system in the platform
- Manual platform lowering valve
- Integrated forklift pockets
- Towing hooks
- Horn
- Hour meter

OPTIONS AND ACCESSORIES

- Flashing beacon
- Alarm package (descent and travel)
- 70 W platform work light

