



COMPACT 2032 E COMPACT 2632 E

Optimum compactness

- Width of 2 ft 7 in to operate in the most congested areas
- Compact stowed height for easy access through standard doorways

Exceptional productivity

- Load capacity up to 770 lbs (Compact 2032 E)
- Driveable at full height
- Extended platform
- Long working cycles

Reliable and easy to maintain



Haulotte 
GROUP

More than lifting





COMPACT 2032 E / COMPACT 2632 E

ELECTRIC SCISSOR LIFTS

TECHNICAL DATA

COMPACT 2032 E **COMPACT 2632 E**

Working height	26 ft 4 in	32 ft 3 in
Platform height	20 ft 4 in	26 ft 3 in
Driveable at full height up to	20 ft 4 in	26 ft 3 in
Lift capacity - inside	770 lbs	500 lbs
Lift capacity - outside	265 lbs	N/A
A Platform length - outside	7 ft 7 in	7 ft 7 in
B Platform length - extended	10 ft 7 in	10 ft 7 in
Extension length	3 ft	3 ft
C Platform width - outside	2 ft 8 in	2 ft 8 in
E Storage height	3 ft 8 in	4 ft 4 in
D Height - stowed	6 ft 7 in	7 ft 2 in
F Overall width	2 ft 8 in	2 ft 8 in
G Length	8 ft 2 in	8 ft 2 in
H Wheelbase	6 ft 1 in	6 ft 1 in
I Ground clearance	5 in	5 in
Ground clearance - Pothole guards deployed	1 in	1 in
Drive speed	0.6 - 2.1 mph	0.6 - 2.0 mph
Gradeability	23 %	23 %
Lift / lower speed	26 s / 37 s	36 s / 42 s
Turning radius - outside	7 ft 10 in	7 ft 10 in
Non-marking tires	15x5	15x5
Batteries	24 V - 260 Ah (C20)	24 V - 260 Ah (C20)
Hydraulic system capacity	7.1 gal	7 gal
Weight	3,649 lbs	4,829 lbs

Compact 2032 E Compact 2632 E

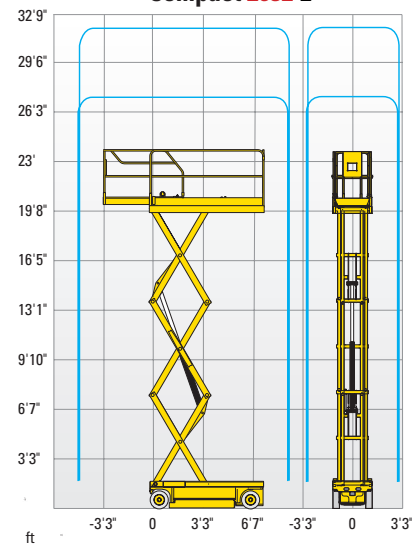

STANDARD EQUIPMENT

- Pothole protection
- Battery charge indicator
- Proportional lift and drive
- Fold down guardrails (2632 E)
- Slideout battery compartment
- Battery charger 110V / 60Hz
- Non-marking tires
- Free wheeling device
- Tilt alarm
- Load management system in the platform
- Manual platform lowering valve
- Forklift pockets
- Towing hooks
- Horn
- Hour meter

OPTIONS AND ACCESSORIES

- Flashing beacon
- Motion alarm (travel and elevate)
- 70 W platform working light
- Folding guardrails (2032E)

