



Operators Manual

Central Mobile Enclosure 600 GTS Series

Aug/08

DRYAIR MANUFACTURING CORP.
400 Service Road,
St. Brieux, SK., Canada, S0K 3V0,
Tel: 306-275-4848 1-888-750-1700
Fax: 306-275-4664
dryair@dryair.ca

DRYAIR MANUFACTURER CORP.
1095 N. Main Street
Bowling Green, Ohio, USA, 43402
Tel: 419-354-8546 1-866-354-8546
Fax: 419-354-9706
dryair@dryair.us

Table of Contents

Warranty Policies & Claim Procedures	1-1
Warranty Policies	1-1
Warranty Claim Procedure	1-2
Safety Concerns	2-1
General Safety Guidelines	2-1
Water Heater Module	2-1
Heat Transfer Fluid	2-1
Material Safety Data Sheet - Boss Chill PG	2-2
Material Safety Data Sheet - Dowfrost*	2-5
Introduction	3-1
Components	3-1
Central Mobile Enclosure	3-1
Passive heat transfer	3-2
Accessories	3-2
How the system works	3-3
Setup (CME)	4-1
Required safety clearances	4-1
Elevation concerns	4-1
Electrical requirements & connection	4-2
Heat transfer fluid “HTF”	4-2
Fuel	4-3
Primary “HTF” circulation lines	4-3
Burner Removal	4-3
Burner Installation	4-3
Operation (CME)	5-1
Purging air from the “HTF” circulation system	5-1
Before firing the system	5-2
Cold start procedure	5-3
Temperate start procedure	5-4
Purging air from the fuel system	5-5
Adding “HTF” to system	5-6
Setup/Operation (HR2250)	6-1
Manual Controls	6-1
Mechanical Drive Components	6-2
Troubleshooting (CME)	7-1
Maintenance	8-1
Central Heating Module	8-1
HR2250	8-3
Appendum	9-1
Important Certification & Operational Information Decals	9-1
Non-pressure vessel decal	9-1
Certification & Heater Specifications	9-2
Electrical schematics	9-3

Warranty Policies & Claim Procedures

DRYAIR MANUFACTURING CORP. (referred to within as DRYAIR) warrants its new, unused equipment to be free of defects in material and workmanship at the time of delivery to the first retail purchaser.

Warranty Policies

Basic warranty policy

- DRYAIR will repair or replace, at its option, without charge, any defective part of the equipment for a period of twelve (12) months from delivery to the first retail purchaser, F.O.B St. Brieux, SK., Canada or Bowling Green, Ohio.
- Mileage is not covered. Any parts that are covered by an extended warranty published by DRYAIR are an exception to the Basic Warranty policy and are to be warranted as per the details of the Extended Warranty Policy.
- Labor is covered as per DRYAIR flat labor rate.
- The Warranty Policy, terms and conditions, may change from time to time without prior notice.
- Warranty terms and conditions are transferable in the event of the sale to a second owner.
- Replacement parts will be warranted for 90 days from the repair date. Bill of sale must accompany the warranty claim.

Extended warranty policy

Water heater heat exchanger

- An extended warranty is available on the heat exchanger unit of the water heater assembly. The available warranty for a part, under the extended warranty policy, is prorated by 20% per year.
- (Shipment date is the date to be used for the commencement of the warranty period).
- Coverage schedule
 - Year 1 - 100%
 - Year 2 - 80%
 - Year 3 - 60%
 - Year 4 - 40%
 - Year 5 - 20%

Exceptions to the warranty policies

- Under no circumstance shall the owner be entitled to recover costs for incidental, special or consequential damages such as, but not limited to: loss of profit or revenue, other commercial losses, inconvenience and/or replacement equipment rental cost.
- Maintenance, repair or service items not related to warrantable defects.
- Loss or damage during shipping.
- Failure resulting from lack of or improper maintenance.
- Damage caused by operator abuse, negligence or improper operation.
- Damage resulting from improper voltage supply.
- Damage from improper installation. Installation done by other than the manufacturer.
- Non-defective items replaced at the request of the customer.
- Damage due to accidents.
- Damage resulting from improper fuel supply (i.e. pressure or contamination).
- Damage resulting from cracked or broken lines occurring during transport.
- Damage resulting from use of inadequate or improper fluids (i.e.. glycol or oil).

Owners obligations

- It is the responsibility of the owner, at the owner's expense, to transport the equipment to the service facility of an authorized DRYAIR distributor/dealer or alternately to reimburse the distributor/dealer, for any traveling expenses incurred in fulfilling this warranty.
- The terms of this Warranty Policy are subject to provincial and state legislation. DRYAIR reserves the right to make modifications in accordance with provincial and state legislation without prior notice or obligation.
- It is the responsibility of the owner to read, understand and implement the maintenance, safety and operational guidelines as laid out in the Operation and Maintenance Guide.
- All parts to be tagged with warranty claim number and shipped prepaid to DRYAIR within 30 days.

Manufacturer obligations

- DRYAIR reserves the right to continually improve and/or change the product's parts or specifications at any time without notice or obligation.
- The terms of this Warranty Policy are subject to provincial and state legislation. DRYAIR reserves the right to make modifications in accordance with provincial and state legislation without prior notice or obligation.

Warranty Claim Procedure

- All warranty credits must be processed with the DRYAIR Warranty Claim Form.
- All warranty parts, unless otherwise specified, are to be returned to DRYAIR Inc. along with a completed Warranty Claim Form.

Note: Prior to returning warranty parts, please call for an authorization number and shipping instructions from the Warranty department in Canada.

- Location of Warranty Depots

USA

DRYAIR MANUFACTURER CORP.
1095 N. Main Street
Bowling Green, OH
43402
Ph. 1 (866) 354-8546

Canada

DRYAIR MANUFACTURING CORP.
400 Service Road
Box 126
St. Brieux, SK
S0K 3V0
Ph. 1 (888) 750-1700

- Each warranty claim should only refer to one Serial or Production Schedule numbered unit.
- Warranty parts are to be tagged with warranty claim number.
- When claiming for warranty labour, the allowable warranty labour rate will be \$45.00/hour. The factory reserves the right to adjust the number of hours claimed where deemed necessary.
- The factory may at times specify allowable labour for certain warranty procedures.
- Mileage and travel time, to and from the customer are not eligible for warranty credit.
- Freight charges for warranty parts are not eligible for warranty credit.
- Labour flat rates for component changes
 - Electrical components - .5 hour
 - Plumbing components - 1 hour
 - Electric motor changes - 1 hour

Note: Other labour charges will be at the discretion of DRYAIR.

Safety Concerns

General Safety Guidelines

- Make certain that the operator reads and understands all the information in this manual.
- All unauthorized people must be kept away from the equipment when in operation.
- Maintain instructional and safety decals. Replace damaged decals.
- All guards must be in place when the equipment is in operation.

Water Heater Module

CAUTION! The water heater is a heating appliance.

- When dealing with any heating appliance, observe all posted warnings and cautions.
- Keep children and pets away from all piping and fuel accessories.
- The water heater housing panels must be kept closed when the system is operating. This prevents drafts from affecting water heater operation.

Heat Transfer Fluid

Follow the following precautions and measures when working with “heat transfer fluid” (“DOWFROST* HTF” & “BOSS CHILL PG”).

Fluid handling precautions

- Ventilation Good general ventilation should be sufficient for most conditions.
- Respiratory protection . No respiratory protection should be needed.
- Skin protection For brief contact, no precautions other than clean body-covering clothing should be needed.
..... Use impervious gloves when prolonged or frequently repeated contact should occur.
- Eye Protection Use safety glasses.

First aid measures

- Eyes Flush eyes with plenty of water.
- Skin Wash off in flowing water or shower.
- Ingestion Induce vomiting if large amounts are ingested.
..... Consult medical personnel.
- Inhalation Remove to fresh air if effects occur.
..... Consult a physician.
- Note to physician No specific antidote.
..... Supportive care.
..... Treatment based on judgment of the physician in response to reactions of the patient.

For complete “heat transfer fluid” information, refer to the Material Safety Data Sheets for “Dowfrost HTF” & “Boss Chill PG” on the following pages.

Material Safety Data Sheet - Boss Chill PG

BOSS CHILL PG MSDS

Canadian Centre for Occupational Health and Safety

Issue: 2001-4 (November, 2001)

MATERIAL SAFETY DATA

1. CHEMICAL PRODUCT & COMPANY IDENTIFICATION

PRODUCT NAME: PROPYLENE GLYCOL INDUSTRIAL
PRODUCT CODE: 70511
EFFECTIVE DATE: 05/23/03 DATE PRINTED 10/09/03 MSD: 000248
COMPANY IDENTIFICATION: The Dow Chemical Company, Midland, MI 48674
EMERGENCY TELEPHONE NUMBER: . 24-HOUR EMERGENCY PHONE NUMBER 989-636-4400
..... Customer Information Center: 800-258-2436

2. COMPOSITION/INFORMATION ON INGREDIENTS

Propylene glycol CAS# 000057-55-6 99%

3. HAZARDS IDENTIFICATION

EMERGENCY OVERVIEW: Colorless, odorless liquid. Toxic fumes released in fire situations.
POTENTIAL HEALTH EFFECTS: (See Section 11 for toxicological data.)
EYE: May cause slight transient (temporary) eye irritation. Corneal injury is unlikely. Mists may cause eye irritation.
SKIN: Prolonged contact is essentially nonirritating to skin. A single prolonged skin exposure is not likely to result in the material being absorbed through skin in harmful amounts. Repeated exposures may cause flaking and softening of skin. May be absorbed in potentially harmful amounts when applied in large quantities to severe burns (second or third degree) over large areas of the body as part of a cream or other topical application. Absorption under such circumstances can elevate serum osmolality and may result in osmotic shock.
INGESTION: Single dose oral toxicity is considered to be extremely low. No hazards anticipated from swallowing small amounts incidental to normal handling operations.
INHALATION: At room temperature, vapors are minimal due physical properties. Mists may cause irritation of upper respiratory tract.
SYSTEMATIC: (OTHER TARGET ORGAN) EFFECTS: Repeated excessive ingestion may cause central nervous system effects.
CANCER INFORMATION: Did not cause cancer in long-term animal studies.
TERATOLOGY (BIRTH DEFECTS): Birth defects are unlikely. Exposures having no adverse effects on the mother should have no effect on the fetus.
REPRODUCTIVE EFFECTS: In animal studies, has been shown not to interfere with reproduction.

4. FIRST AID

EYE: Flush eyes with plenty of water.
SKIN: Wash off in flowing water or shower.
INGESTION: No adverse effects anticipated by this route of exposure incidental to proper industrial handling.
INHALATION: Remove to fresh air if effects occur. Consult a physician
NOTE TO PHYSICIAN: No specific antidote. Supportive care. Treatment based on judgment of the physician in response to reactions of the patient.

5. FIRE FIGHTING MEASURES

FLASH POINT: 218°F, 103°C
METHOD USED: PMCC
FLAMMABLE LIMITS LFT: 2.6%
LFL: 2.6%
UFL: 12.5%
HAZARDOUS COMBUSTION PRODUCTS: During a fire, smoke may contain the original material in addition to unidentified toxic and/or irritating compounds. Hazardous combustion products may include and are not limited to: aldehydes, carbon monoxide.
OTHER FLAMMABILITY INFORMATION: Violent steam generation or eruption may occur upon application of direct water stream to hot liquids. Spills of these organic liquids on hot fibrous insulations may lead to lowering of the autoignition temperatures possibly resulting in spontaneous combustion.
EXTINGUISHING MEDIA: Water fog or fine spray, carbon dioxide, dry chemical, foam. Alcohol resistant foams (ATC type) are preferred if available. General purpose synthetic foams (including AFFF) or protein foams may function, but much less effectively. Do not use direct water stream. Will spread fire.
MEDIA TO BE AVOIDED: Do not use direct water stream.
FIRE FIGHTING INSTRUCTIONS: Keep people away. Isolate fire area and deny unnecessary entry. Burning liquids may be moved by flushing with water to protect personnel and minimize property damage. Burning liquids may be extinguished by dilution with water. Do not use direct water stream. May spread fire.
PROTECTIVE EQUIPMENT FOR FIRE FIGHTERS: Wear positive-pressure, self-contained breathing apparatus (SCBA) and protective fire-fighting clothing (including fire-fighting helmet, coat, pants, boots, and gloves). If protective equipment is not available or not used, fight fire from a protected location or safe distance.

6. ACCIDENTAL RELEASE MEASURE (See Section 15 for Regulatory Information)

PROTECT PEOPLE: Isolate area.

PROTECT THE ENVIRONMENT: Contain liquid to prevent contamination of soil, surface water or ground water.

CLEANUP: For small spills, clean up with absorbent material. Collect material in suitable and properly labeled open containers. For large spills, dike and pump into suitable and properly labeled containers.

7. HANDLING AND STORAGE

HANDLING: Product handled hot may require additional ventilation or local exhaust. Product on surfaces can cause slippery conditions.

STORAGE: Keep containers tightly closed when not in use. Store in stainless steel, aluminum, Plasteel 3066 lined containers or 316 stainless steel. Store below 121°C, 250° F.

8. EXPOSURE CONTROLS/PERSONAL PROTECTION

ENGINEERING CONTROLS: Provide general and/or local exhaust ventilation to control airborne levels below exposure guidelines.

PERSONAL PROTECTIVE EQUIPMENT

EYE/FACE PROTECTION: Use safety glasses. Safety glasses should be sufficient for most operations; however, for misty operations wear chemical goggles.

SKIN PROTECTION: For brief contact, no precautions other than clean body-covering clothing should be needed. Use impervious gloves when prolonged or frequently repeated contact could occur.

RESPIRATORY PROTECTION: Atmospheric levels should be maintained below the exposure guideline. When respiration protection is required for certain operations, use an approved air-purifying respirator. In misty atmospheres, use an approved mist respirator.

EXPOSURE GUIDELINE(S): Propylene glycol: AIHA WEEL is 50 ppm total, 10 mg/m³ aerosol only.

9. PHYSICAL AND CHEMICAL PROPERTIES

APPEARANCE: Colorless liquid
ODOR: Odorless
VAPOR PRESSURE: 0.08 mmHg @ 20°C, 68°F
VAPOR DENSITY: 2.62
BOILING POINT: 370°F, 188°C
SOLUBILITY IN WATER: Complete
SPECIFIC GRAVITY: 1.038 @ 20/20°C, 68°F

10. STABILITY AND REACTIVITY

CHEMICAL STABILITY: Stable.

CONDITIONS TO AVOID: Avoid temperatures above 121°C/250°F. Product can decompose at elevated temperatures.

INCOMPATIBILITY WITH OTHER MATERIALS: Avoid contact with oxidizing materials.

HAZARDOUS DECOMPOSITION PRODUCTS: When available oxygen is limited, as in a fire or heated to very high temperatures by hot wire or plate, carbon monoxide and other hazardous compounds such as aldehydes might be generated,

HAZARDOUS POLYMERIZATION: Will not occur.

11. TOXICOLOGICAL INFORMATION (See Section 3 for Potential Health Effects. For detailed toxicological data, write or call the address or non-emergency number shown in section 1)

SKIN: the LD50 for skin absorption in rabbits is greater than 10,000 mg/kg.

INGESTION: The oral LD50 for Female rats is about 20,000-34,000mg/kg.

MUTAGENICITY (EFFECTS ON GENETIC MATERIAL): Results of in vitro (test tube) mutagenicity tests have been negative. Results of mutagenicity tests in animals have been negative.

12. ECOLOGICAL INFORMATION (For detailed Ecological data, write or call the address or non-emergency number shown in Section 1)

ENVIRONMENTAL FATE

MOVEMENT AND PARTITIONING: Based largely or completely on information for similar material(s), i.e. propylene glycol. Bioconcentration potential is low (BCF less than 100 or Log Pow less than 3). Log octanol/water partition coefficient (log Pow) is -0.92. Henry's Law Constant (H) is 1.2E-8 atm.m³/mole.

DEGRADATION AND PERSISTENCE: Based largely or completely on information for similar material(s), i.e. propylene glycol. Biodegradation under aerobic static laboratory conditions is high (BOD20 or BOD28/ThOD greater than 40%). Biodegradation is expected to be achieved in a secondary waste-water treatment plant. 5-Day biochemical oxygen demand (BOD5) is 1.16 p/p. 20-Day biochemical oxygen demand (BOD20) is 1.45 p/p. Theoretical oxygen demand (ThOD) is calculated to be 1.68 p/p. Inhibitory concentration (IC50) in OECD Activated Sludge Respiration Inhibition Test (OECD Test No. 209) is greater than 1gm/L. Degradation is expected in the atmospheric environment within minutes to hours.

ECOTOXICITY: Based largely or completely on information for similar material(s), i.e. propylene glycol. Material is practically non-toxic to aquatic organisms on an acute basis (LC50 greater than 100 mg/L in most sensitive species).

Acute LC50 for fathead minnow (*Pimephales promelas*) is 46500-54900 mg/L.

Acute LC50 for guppy (*Poecilia reticulata*) is greater than 10000 mg/L.

Acute LC50 for water flea *Daphnia magna* is 4850-34400 mg/L.

Acute LC50 for rainbow trout (*Oncorhynchus mykiss*) is 44 ml/L (about 44000 mg/L).

13. DISPOSAL CONSIDERATION (See Section 15 for Regulatory Information)

DISPOSAL: DO NOT DUMP INTO ANY SEWERS, ON THE GROUND OR INTO ANY BODY OF WATER. All disposal methods must be in compliance with all Federal, State/Provincial and local laws and regulations. Regulations may vary in different locations. Waste characterizations and compliance with applicable laws are the responsibility solely of the waste generator. THE DOW CHEMICAL COMPANY HAS NO CONTROL OVER THE MANAGEMENT PRACTICES OR MANUFACTURING PROCESS OF PARTIES HANDLING OR USING THIS MATERIAL. THE INFORMATION PRESENTED HERE PERTAINS ONLY TO THE PRODUCT AS SHIPPED IN ITS INTENDED CONDITION AS DESCRIBED IN MSDS SECTION 2 (Composition/Information on Ingredients).

FOR UNUSED & UNCONTAMINATED PRODUCT, the preferred options include sending to a licensed, permitted: recycler, reclaimer, incinerator or waste water treatment system.

As a service to its customers, Dow can provide names of information resources to help identify waste management companies and other facilities which recycle, reprocess or manage chemicals or plastics, and that manage used drums. Telephone Dow's Customer Information Centre at 800-258-2436 or 989-832-1556 for further details.

14. TRANSPORT INFORMATION

DEPARTMENT OF TRANSPORT:

This product is not regulated by D.O.T. when shipped domestically by land

CANADIAN TDG INFORMATION:

For TDG regulatory information, if required, consult transportation regulations, product shipping papers, or your Dow representative.

15. REGULATORY INFORMATION (Not meant to be all-inclusive—selected regulations represented)

NOTICE: The information herein is presented in good faith and believed to be accurate as of the effective date shown above. However, no warranty, express or implied is given. Regulatory requirements are subject to change and may differ from one location to another; it is the buyer's responsibility to ensure that its activities comply with federal, state or provincial, and local laws. The following specified information is made for the purpose of complying with numerous federal, state or provincial, and local laws and regulations. See other sections for health and safety information.

U.S. REGULATION

SARA 313 INFORMATION: To the best of our knowledge, this product contains no chemical subject to SARA Title III Section 313 supplier notification requirements.

SARA HAZARD CATEGORY: This product has been reviewed according to the EPA "Hazard Categories" promulgated under Sections 311 and 312 of the Superfund Amendment and Reauthorization Act of 1986 (SARA Title III) and is considered, under applicable definitions, to meet the following categories: Not to have met any hazard category.

TOXIC SUBSTANCES CONTROL ACT (TSCA):

All ingredients are on the TSCA inventory or are not required to be listed on the TSCA inventory.

STATE RIGHT-TO-KNOW: The following product components are cited on certain state lists as mentioned. Non-listed components may be shown in the composition section of the MSDS.

REGULATORY INFORMATION:

<u>CHEMICAL NAME</u>	<u>CAS NUMBER</u>	<u>LIST</u>
1, 2-PROPANEDIOL	00057-55-6	PA 1

PA1=Pennsylvania Hazardous Substance (present at greater than or equal to 1.0%).

OSHA HAZARD COMMUNICATION STANDARD:

This product is not a "Hazardous Chemical" as defined by the OSHA Hazard Communication Standard, 29 CFR 1910.1200.

CANADIAN REGULATIONS

WHMIS INFORMATION: The Canadian Workplace Hazardous Materials Information System (WHMIS) classification for this product is: This product is not a "Controlled Product" under WHMIS.

16. OTHER INFORMATION

NATIONAL FIRE PROTECTION ASSOCIATION (NFPA) RATINGS:

Health	0
Flammability	1
Reactivity	0

MSDS STATUS: Revised Section 16.

* or ® Indicates a Trademark of The Dow Chemical Company

The Information Herein Is Given In Good Faith, But No Warranty, Express or Implied, Is Made. Consult The Dow Chemical Company For Further Information.

Material Safety Data Sheet - Dowfrost*

DOWFROST* HEAT TRANSFER FLUID MSDS

Canadian Centre for Occupational Health and Safety

Issue: 05/09/2002

Received: 09/10/2003

MATERIAL SAFETY DATA

1. CHEMICAL PRODUCT & COMPANY IDENTIFICATION

PRODUCT NAME: DOWFROST* HEAT TRANSFER FLUID
MSDS#: 1376
EFFECTIVE DATE: 05/09/2002
COMPANY IDENTIFICATION: The Dow Chemical Company
..... Midland, MI 48674
EMERGENCY TELEPHONE NUMBER: . 24-HOUR EMERGENCY TELEPHONE NUMBER: (989)636-4400
..... Customer Information Number: 1-800-258-2436

2. COMPOSITION/INFORMATION ON INGREDIENTS

Propylene glycol	CAS# 000057-55-6	> 99%
Demineralized water	CAS# 007732-18-5	< 5%
Dipotassium hydrogen phosphate	CAS#007758-11-4	< 5%

3. HAZARDS IDENTIFICATION

EMERGENCY OVERVIEW: Colorless, liquid, mild odor. No significant hazards for emergency response are known.
POTENTIAL HEALTH EFFECTS (See Section 11 for toxicological information and additional information about potential health effects.)

EFFECTS OF SINGLE ACUTE OVEREXPOSURE

INHALATION: At room temperature, exposure to vapor is minimal due to low volatility. Mist may cause irritation of upper respiratory tract (nose and throat).
EYE CONTACT: May cause slight temporary eye irritation. Corneal injury is unlikely.
SKIN CONTACT: Prolonged contact is essentially nonirritating to skin. Repeated contact may cause flaking and softening of skin.
SKIN ABSORPTION: Prolonged skin contact is unlikely to result in absorption of harmful amounts.
SWALLOWING: Very low toxicity if swallowed. Harmful effects not anticipated from swallowing small amounts

POTENTIAL ENVIRONMENTAL EFFECTS (See Section 12 for Ecological Information)

4. FIRST AID

INHALATION: Move person to fresh air; if effects occur, consult a physician.
EYE: Flush eyes thoroughly with water for several minutes. Remove contact lenses after the initial 1-2 minutes and continue flushing for several additional minutes. If effect occur, consult a physician, preferably an ophthalmologist.
SKIN: Wash skin with plenty of water
INGESTION: No emergency medical treatment necessary.
NOTE TO PHYSICIAN: No specific antidote. Treatment of exposure should be directed at the control of symptoms and the condition of the patient.

5. FIRE FIGHTING MEASURES

FLAMMABLE PROPERTIES (Refer to section 9, PHYSICAL AND CHEMICAL PROPERTIES)

EXTINGUISHING MEDIA: Water fog or fine spray. Dry chemical fire extinguishers. Carbon dioxide fire extinguishers. Foam. Do not use direct water stream. May spread fire. Alcohol resistant foams (ATC type) are preferred. General purpose synthetic foams (including AFFF) or protein foams may function, but will be less effective.

FIRE FIGHTING PROCEDURES: Keep people away. Isolate fire area and deny unnecessary entry. Use water spray to cool fire exposed containers and fire affected zone until fire is out and danger of reignition has passed. Fight fire from a protected location or safe distance. Consider the use of unmanned hose holders or monitor nozzles. Immediately withdraw all personnel from the area in case of rising sound from venting safety device or discoloration of the container. Burning liquids may be extinguished by dilution with water. Do not use direct water stream. May spread fire. Move container from fire area if this is possible without hazard. Burning liquids may be moved by flushing with water to protect personnel and minimize property damage.

SPECIAL PROTECTIVE EQUIPMENT FOR FIRE FIGHTERS: Wear positive-pressure self-contained breathing apparatus (SCBA) and protective fire-fighting clothing (including fire-fighting helmet, coat, pants, boots, and gloves). If protective equipment is not available or not used, fight fire from a protected location or safe distance.

UNUSUAL FIRE AND EXPLOSION HAZARDS: Container may rupture from gas generation in a fire situation. Violent steam generation or eruption may occur upon application of direct water stream to hot liquids. Liquid mist of this product can burn. Flammable concentrations of vapor can accumulate at temperatures above flash point; see Section 9.

HAZARDOUS COMBUSTION PRODUCTS: During a fire, smoke may contain the original material in addition to combustion products of varying composition which may be toxic and/or irritating. Combustion products may include and are not limited to: Carbon monoxide. Carbon dioxide.

6. ACCIDENTAL RELEASE MEASURE

SMALL SPILLS: Absorb with materials such as: cat litter, sawdust, vermiculite, Zorb-all. Collect in suitable and properly labeled containers.

LARGE SPILLS: Dike area to contain spill. Recover spilled material if possible. See Section 13, Disposal Considerations for additional information.

PERSONAL PRECAUTIONS: Use appropriate safety equipment. For additional information, refer to Section 8, Exposure Controls and Personal Protection.

ENVIRONMENTAL PRECAUTIONS: Prevent from entering into soil, ditches, sewers, waterways and/or groundwater. See Section 12, Ecological Information.

7. HANDLING AND STORAGE

HANDLING

GENERAL HANDLING: See Section 8, EXPOSURE CONTROLS AND PERSONAL PROTECTION.

VENTILATION: Provide general and/or local exhaust ventilation to control airborne levels below the exposure guidelines.

OTHER PRECAUTIONS: Spills of these organic materials on hot fibrous insulations may lead to lowering of the autoignition temperatures possibly resulting in spontaneous combustion.

STORAGE: 121°C (250° F). Do not store in: galvanized steel.

8. EXPOSURE CONTROLS AND PERSONAL PROTECTION

EXPOSURE LIMITS

<u>COMPONENT</u>	<u>EXPOSURE LIMITS</u>	<u>SKIN FORM</u>
Propylene glycol	10mg/m3 TWA8 AIHA WEEL 50 ppm TWA8 AIHA WEEL	Aerosol Total Particulate fume

In the Exposure Limits Chart above, if there is no specific qualifier (i.e., Aerosol) listed in the Form Column for a particular limit, the listed limit includes all airborne forms of the substance that can be inhaled.

PERSONAL PROTECTION

RESPIRATORY PROTECTION: Atmospheric levels should be maintained below the exposure guideline.

PROTECTION: When respiratory protection is required for certain operations, use an approved air-purifying respirator. In dusty or misty atmospheres, use an approved particulate respirator.

EYE PROTECTION: Use safety glasses.

OTHER PROTECTIVE EQUIPMENT: No precautions other than body-covering clothing should be needed. Use gloves chemically resistant to this material.

9. PHYSICAL AND CHEMICAL PROPERTIES

PHYSICAL STATE: Liquid
APPEARANCE: Colorless
ODOR: Mild
FLASH POINT - Closed Cup: 102°C 216°F Tag closed cup ASTM D 56 (Propylene glycol)
FLAMMABLE LIMITS IN AIR: Lower 2.6%(V) 100°C (Propylene glycol)
..... Upper 12.5%(V) 130°C (Propylene glycol)
AUTOIGNITION TEMP: 416°C 780°F
VAPOR PRESSURE: 0.7 mmHg @ 20°C, 68°F
BOILING POINT (760 mmHg): 162°C 323°F
VAPOR DENSITY (air=1): 2.6
SPECIFIC GRAVITY (H2O=1):1.05 20°C/20°C
FREEZING POINT: <=-51°C <=-60°F
MELTING POINT: *Not applicable (for liquids)*
SOLUBILITY IN WATER (by weight): 100% 20°C
pH: 9-11 (5% solution in water)
EVAPORATION RATE (Butyl Acetate=1): 0.07
PERCENT VOLATILES: 98 Wt%

10. STABILITY AND REACTIVITY

STABILITY/INSTABILITY: Thermally stable at recommended temperatures and pressures.

CONDITIONS TO AVOID: Product can oxidize at elevated temperatures. Generation of gas during decomposition can cause pressure in closed systems

INCOMPATIBLE MATERIALS: Avoid contact with: Strong acids. Strong bases. Strong oxidizers.

THERMAL DECOMPOSITION: Decomposition products depend upon temperature, air supply and the presence of other materials. Decomposition products can include and are not limited to: Aldehydes. Alcohols. Ethers.

HAZARDOUS POLYMERIZATION: Will not occur

11. TOXICOLOGICAL INFORMATION

ACUTE TOXICITY:

Peroral: Rat; female; LD50 = 20300 mg/kg

Percutaneous: Based on information for a similar material:

Rabbit; LD50 = > 10000 mg/kg

DEVELOPMENT TOXICITY: Contains component(s) which did not cause birth defects or any fetal effects in lab animals., The component(s) is/are:;

REPRODUCTIVE TOXICITY: Contains component(s) which did not interfere with reproduction in animal studies., Contains component(s) which did not interfere with fertility in animal studies., The component(s) is/are:; Propylene glycol.

CHRONIC TOXICITY AND CARCINOGENICITY: Similar formulations did not cause cancer in laboratory animals.

GENETIC TOXICOLOGY:

In Vitro: In Vitro mutagenicity studies were negative.

In Vivo: Mutagenicity studies in animals were negative for component(s) tested

SIGNIFICANT DATA WITH POSSIBLE RELEVANCE TO HUMANS: In rare cases, repeated excessive exposure to propylene glycol may cause central nervous system effects.

12. ECOLOGICAL INFORMATION

ENVIRONMENTAL FATE: Based largely or completely on information for: Propylene glycol. Material is readily biodegradable.

Passes OECD test(s) for ready biodegradability. Degradation is expected in the atmospheric environment within minutes to hours.

ECOTOXICITY: Based largely or completely on information for: Propylene glycol. Material is practically non-toxic to aquatic organisms on an acute basis (LC50/EC50 . 100mg/L in most sensitive species tested).

FURTHER INFORMATION: Based largely or completely on information for: Propylene glycol. Bioconcentration potential is low (BCF < 100 or Log Pow < 3). Potential for mobility in soil is very high (Koc between 0 and 50).

13. DISPOSAL CONSIDERATION (See Section 15 for Regulatory Information)

DISPOSAL: DO NOT DUMP INTO ANY SEWERS, ON THE GROUND OR INTO ANY BODY OF WATER. All disposal practices must be in compliance with all Federal, State/Provincial and local laws and regulations. Regulations may vary in different locations. Waste characterizations and compliance with applicable laws are the responsibility solely of the waste generator. THE DOW CHEMICAL COMPANY HAS NO CONTROL OVER THE MANAGEMENT PRACTICES OR MANUFACTURING PROCESS OF PARTIES HANDLING OR USING THIS MATERIAL. THE INFORMATION PRESENTED HERE PERTAINS ONLY TO THE PRODUCT AS SHIPPED IN ITS INTENDED CONDITION AS DESCRIBED IN MSDS SECTION 2 (Composition/Information on Ingredients). FOR UNUSED & UNCONTAMINATED PRODUCT, the preferred options include sending to a licensed, permitted: recycler, reclaimer, incinerator or other thermal destructive device. As a service to its customers, Dow can provide names of information resources to help identify waste management companies and other facilities which recycle, reprocess or manage chemicals or plastics, and that manage used drums. Telephone Dow's Customer Information Centre at 1-800-258-2436 or 0-989-832-1556 (U.S.), or 1-800-331-6451 (Canada) for further details.

14. TRANSPORT INFORMATION

NON-BULK Proper Shipping Name: NOT REGULATED

BULK Proper Shipping Name: NOT REGULATED

The information is not intended to convey all specific regulatory or operational requirements/information relating to this product. Additional transportation system information can be obtained through an authorized sales or customer service representative. It is the responsibility of the transportation organization to follow all applicable laws, regulations and rules relating to the transportation of the material.

15. REGULATORY INFORMATION (Not meant to be all-inclusive—selected regulations represented)

FEDERAL/NATIONAL

OSHS Hazard Communication Standard

This product is not a "Hazardous Chemical" as defined by the OSHA Hazard Communication Standard, 29 CFR 1910.1200.

Superfund Amendments and Reauthorization Act of 1986 Title III (Emergency Planning and Community Right To Know Act) Section 313
To the best of our knowledge this product does not contain chemicals at levels which require reporting under this statute.

Superfund Amendments and Reauthorization Act of 1986 Title III (Emergency Planning and Community Right To Know Act) Section 302
To the best of our knowledge this product does not contain chemicals at levels which require reporting under this statute.

Superfund Amendments and Reauthorization Act of 1986 Title III (Emergency Planning and Community Right To Know Act) Section 311 & 312

Delayed (Chronic) Health Hazard: NO

Fire Hazard: NO

Immediate (Acute) Health Hazard: NO

Reactive Hazard: NO

Sudden Release of pressure Hazard: NO

Toxic Substance Control Act (TSCA)

All components of this product are on the TSCA Inventory or are exempt from TSCA Inventory requirements.

CEPA - Domestic Substances List (DSL)

All substances contained in this product are listed on the Canadian Domestic Substances List (DSL) or are not required to be listed.

European Inventory of Existing Commercial Chemical Substances (EINECS)

The components of this product are on the EINECS inventory or are exempt from EINECS inventory requirements.

STATE/LOCAL

Pennsylvania (Worker and Community Right To Know Act): Pennsylvania Hazardous Substances List and/or Pennsylvania Environmental Hazardous Substance List:

The following product components are cited in the Pennsylvania Hazardous Substance List and/or the Pennsylvania Environmental Substance List, and are present at levels which require reporting.

<u>COMPONENT</u>	<u>CAS#</u>	<u>AMOUNT</u>
Propylene glycol	57-55-6	96.0000 %

Pennsylvania (Worker and Community Right To Know Act): Pennsylvania Special Hazardous Substances List:

To the best of our knowledge this product does not contain chemicals at levels which require reporting under this statute.

California Proposition 65 (Safe Drinking Water and Toxic Enforcement Act of 1986)

This product contains no listed substances known to the State of California to cause cancer, birth defects of other reproductive harm, at levels which would require a warning under the statute.

California SCAQMD Rule 443.1 (South Coast Air Quality Management District Rule 443.1, Labeling of Material Containing Organic Solvents).

VOC: Vapor pressure 0.66 mmHg @ 20°C
1002 g/l VOC
1030 g/l less water and less exempted solvents

This section provides selected regulatory information on this product including its components. This is not intended to include all regulations. It is the responsibility of the user to know and comply with all applicable rules, regulations and laws relating to the product being used.

16. OTHER INFORMATION

ADDITIONAL INFORMATION

Additional information on this and other Dow products may be obtained by visiting our web page at www.dow.com.

Additional information on this product may be obtained by calling Dow's Customer Information Group at 1-800-258-2436 (U.S.) or 1-800-331-6451 (Canada)

HAZARD RATING SYSTEM

NFPA rating for this product are: H - 0 F - 0 R - 0

The ratings are part of a specific hazard communication program and should be disregarded where individuals are not trained in the use of this hazard rating system. You should be familiar with the hazard communication programs applicable to your workplace.

RECOMMENDED USES AND RESTRICTIONS

Intended as a heat transfer fluid for closed-loop systems.

Dow recommends that you use this product in a manner consistent with the listed use. If your intended use is not consistent with Dow's Stated use, please contact Dow's Customer Information Group at 1-800-258-2436 (U.S.) or 1-800-331-6451 (Canada) for more information.

REVISION

Version: 4.1
Revision: 05/09/2002

Most recent revision(s) are noted by the bold, double bars in the left-hand margin throughout this document.

LEGEND

Bacteria/NA	Non Acclimated Bacteria
F	Fire
H	Health
IHG	Industrial Hygiene Guidelines
N/A	Not available
NFPA	National Fire Protection Association
O	Oxidizer
R	Reactivity
TS	Trade secret
VOL/VOL	Volume/Volume
W	Water reactive
W/W	Weight/Weight

NOTICE: Dow urges each customer or recipient of this MSDS to study it carefully and consult appropriate expertise, as necessary or appropriate, to become aware of and understand the data contained in this MSDS and any hazards associated with the product. The information herein is provided in good faith and believed to be accurate as of the effective date shown above. However, no warranty, express or implied, is given. Regulatory requirements are subject to change and may differ between various locations. It is the buyer's/user's responsibility to ensure that its activities comply with all federal, state, provincial or local laws. The information presented here pertains only to the product as shipped. Since conditions for use of the product are not under the control of Dow, it is the buyer's/user's duty to determine the condition necessary for the safe use of this product. Due to the proliferation of sources for information such as manufacturer-specific MSDSs, Dow is not and cannot be responsible for MSDSs obtained from any source other than Dow. If you have obtained a Dow MSDS from a non-Dow source or if you are not sure that a Dow MSDS is current, please contact Dow for the most current version.

Introduction

Components

Central Mobile Enclosure

- A compact and portable design.
- Easy access from rear and side doors.
- Automatic temperature control and fuel usage which responds to work site demands.
- Low pressure atmospherically vented circulation system ... no special boiler certification is required to operate the system.
- Circulation system “automatic air vent” component for quick setup-and-go operation.
- A central heat module control center which monitors and controls system operations.
- A multi-light system operation feature for easy system troubleshooting.
- Flow-reversing “Green Thaw” system.



1 - 600 GTS Central Mobile Enclosure (side view)



2 - 600 GTS Central Mobile Enclosure (back view)

Passive heat transfer

Circulation line heat exchangers

The circulation line heat exchangers are the perfect solution for:

- Heating and/or thawing cold or frozen ground.
- Frost prevention.
- Concrete curing and heating in subzero environments.

This system can be applied to all types of concrete applications. Circulation line heat exchangers can be secured directly against the surface of the concrete or concrete forms. Alternately, an expendable circulation line can be incorporated into the concrete structure during the pour. Thus the slab floor can continue being heated, to provide radiant floor heat during construction.

Hose reel

- The onboard hose reel comes with 3000 ft. of 5/8" I.D circulation line heat exchangers hose. The onboard hose reel (HR-2250) can hold up to 4000 ft. of the 5/8" I.D. circulation line heat exchangers.
- The reel provides convenient storage for the "circulation line heat exchange" hose required for thawing and/or curing concrete.
- The electric drive system provides "power on" or "power off" capability.
- A torque-limiting device provides breaking.
- The on-board reel comes with an integral 6-port manifold and a pair of 1 1/2" quick connections to accommodate a remote manifold.

Accessories

Mixing/booster pump

The multifunctional mixing/booster ensures maximum flexibility in the use of this system.

- Tempering mode supplies lower temperature fluid for concrete cure and radiant floor heat applications eliminating the need to reduce the water heater operating temperatures below safe operating ranges.
- When operating in booster mode, the system can increase flow rates or function as a pumping station to increase pumping distances by over 300 feet per station.
- The system also allows for dual-temperature control. High temperature fluid can be provided to portable heat exchangers, along with a lower temperature fluid for concrete cure and radiant floor heat applications.

Optional remote manifold

The multifunctional mixing/booster ensures maximum flexibility in the use of this system.

- Allows for additional distribution and/or separation between the central heating trailer and the manifold.

Insulated line jackets

Insulated circulation line jackets are also available. These insulated jackets will prevent exposed circulation line heat loss in extreme subzero conditions.

Portable heat exchanger

Portable heat exchangers are the ideal way to heat and/or dry enclosed structures. Their compact and mobile design allows them to be positioned where required on the job site. The efficient fan/coil design provides a high rate of heat transfer. High volume fans then deliver this heat evenly throughout a large area. The clean, low relative humidity heat delivery minimizes energy costs by eliminating the need to draw in fresh outside air. With this system, you just reheat warm internal air, rather than heating cold external air.



3 - hose reel

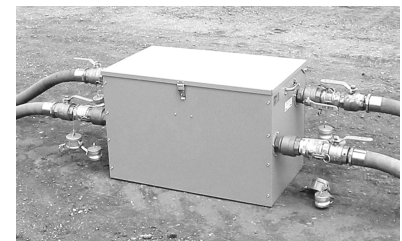

4 - mixing/booster pump

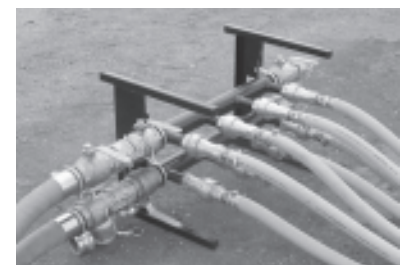

5 - Optional remote manifold & fluid circulation lines



6 - portable heat exchangers

How the system works

The system uses a low-pressure, open fluid loop distribution system with an atmospherically vented fluid reservoir. A central heating module warms the heat transfer fluid. This heated fluid is pumped through a distribution system loop, passing through heat exchangers in remote locations.

Two types of exchangers are available:

- Portable heat exchangers include a heat transfer coil, fan and thermostat temperature control. The heat transfer fluid flows through the transfer coil, where heat is transferred to the air being drawn through the coil by the fan. The coil is specially designed for optimum heat transfer, without adding any moisture or combustion by-products to the air.
- Circulation line heat exchangers use flexible hose with hydraulic-style quick-couplers for ease in hookup. Heat transfer occurs by direct contact heat transfer and radiant heat conduction.

The mixing/booster unit can be utilized to:

- Provide lower temperature fluid for concrete cure and radiant floor heat applications.
- Provide dual temperature control with a single fluid circulation system.
- Boost fluid flow and increase pumping distances.

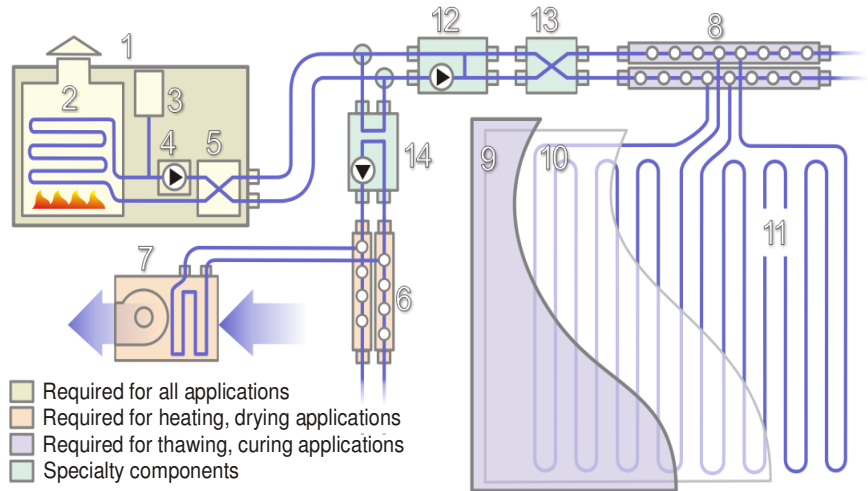

- Required for all applications
- Required for heating, drying applications
- Required for thawing, curing applications
- Specialty components

- | | |
|---|---------------------------------------|
| 1) Heat delivery system* | 8) HTF distribution manifold - 8-port |
| 2) Water heater | 9) Insulated blankets |
| 3) HTF reservoir/atmospheric vent | 10) Vapor barrier |
| 4) Pump | 11) Line heat exchangers |
| 5) Flow reverser (built-in with greenthaw systems only) | 12) Mixing/booster |
| 6) HTF distribution manifold - 4-port | 13) Flow reverser (remote unit) |
| 7) Powered heat exchanger (fluid-to-air exchange) | 14) Plate heat exchanger |

*'Central heating module' (CHM - propane, nat gas or diesel fired) or 'steam plate heat exchanger'

Setup (CME)

The positioning of all the system components on the site will be influenced by a number of factors. Please read all of the “Setup” section before beginning.

Be sure to observe all local electrical codes and fire regulations when positioning the central heat module.

Required safety clearances

The 600 GTS is a heating appliance, therefore safe heat and exhaust clearances must be observed from combustible materials and for service access.

- Maintain 24” (61cm) of clearance on all sides of the unit (1-1).
- Maintain 36” (91cm) of clearance (2-1) on all sides of the flue pipe and chimney cap

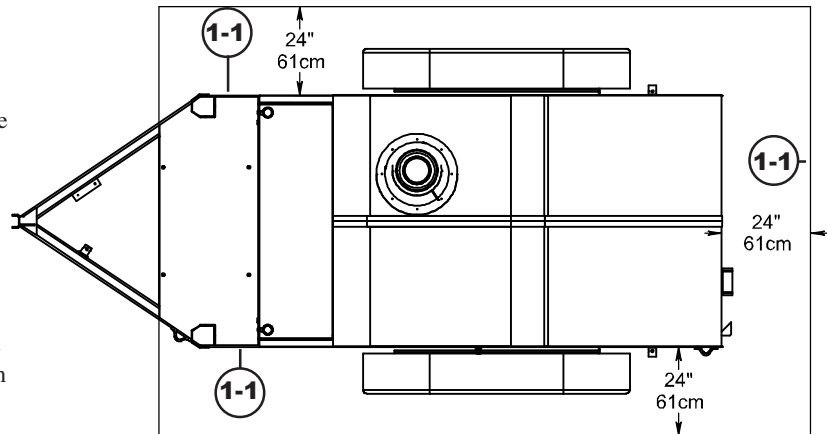

1 - 600 GTS top view

Elevation concerns

Do not place any “portable heat exchangers” or “circulation line heat exchangers” higher than the top level (2-2) of the heat transfer fluid fill tank . If this is not observed, the following can occur:

- Insufficient fluid in the system
Fluid will drain back to the heat transfer fill tank from the over-elevated fluid lines when the pump is shut off. The heat transfer fill tank will show adequate fluid but, when the pump is started, extra fluid will be required to recharge the over-elevated fluid lines and portable heat exchangers and the system will then have insufficient fluid in the reservoir.
- Fluid overflow
If fluid is added to maintain proper fluid levels while the pump is running, overflow at the fill tank will occur when the pump is shut off. This would occur because of drain back from the over-elevated fluid lines.

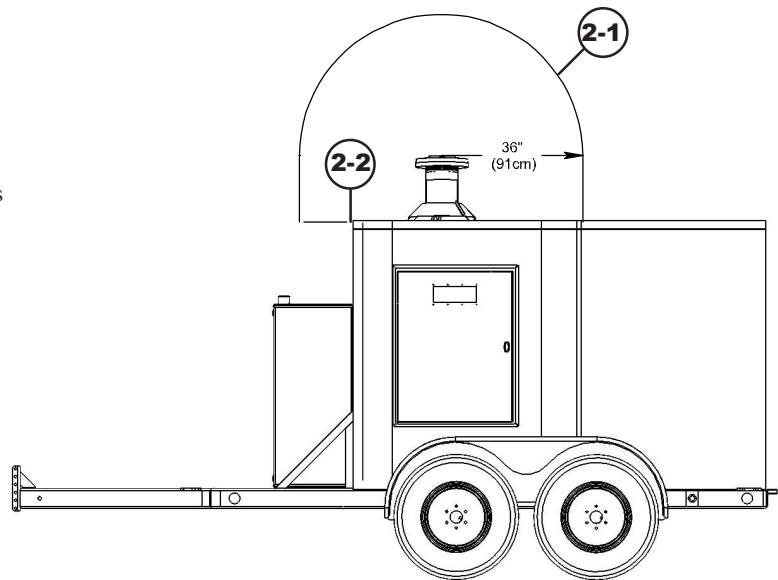

2 - 600 GTS side view

Electrical requirements & connection

When determining the “central mobile enclosure” location on site, consider setting up in close proximity to the electrical power supply.

Note: This applies mainly to systems not equipped with a dedicated generator.

- The 900 GTS’s main feed wiring must be adequately sized to carry the minimum ampacity shown on the water heater cabinet’s rating label. All electrical connections, connectors and wire must be CSA/UL compliant and installed according to local laws and codes.
- Before making any electrical connections, be sure that the electric power supply is “Off”.

900 GTS Electrical Connection (Figure 3):

- The 900 GTS requires 115/230VAC power. The module is factory wired so that the only connection to be made is a 115/230VAC service outlet.
- The main feed wiring must be adequately sized to carry the minimum ampacity shown on the water heater cabinet’s rating label.
- All electrical connections, connectors and wire must be CSA/UL approved, and installed according to local laws and codes.
- A 4-wire hookup (3-1) is required for all systems to work properly. Warranty is void if the wiring hookup is not done correctly.

Heat transfer fluid “HTF”

CAUTION! At no time should you use automobile antifreeze in your system. The use of automobile antifreeze will void your warranty.

- The heat transfer fluid “HTF” level should show no more than 1/4 on the gauge (cold fluid) at start-up. As the “HTF” warms to operating temperature, fluid expansion will raise the level to 1/2 or 3/4 on the gauge (depending on the total volume of fluid in the circulation system).

Heat transfer fluid specifications

- The system is shipped with pre-mixed “HTF”, made up of 50% “Dowfrost ® HTF” or “Boss Chill PG” and 50% water*, by weight - freeze protection down to -28°F (-33°C).
- The “glycol/water mixture chart”, to the right, will provide you with more information on the proper mixture for your area.
- “Dowfrost ® HTF” or “Boss Chill PG” must be used. The pure “Dowfrost ® HTF” or “Boss Chill PG” heat transfer fluid used in the system is made up of a blend of 95-97% Propylene glycol, <5% Dipotassium phosphate and deionized water (see Safety Concerns section - MSDS sheets for additional information).
- Soft water with a neutral pH level (#7) must be used.

CAUTION! Whenever coupling or uncoupling quick couplers, make sure that the isolation valves are closed and the pump is off. Failure to do so may put you at risk of injury from eye and/or skin exposure to hot glycol.

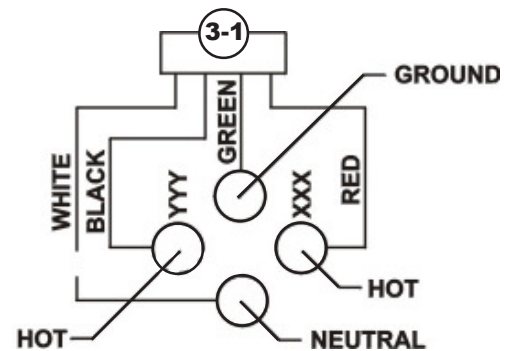

3 - 900 GTS electrical hookup (230VAC)

Percent Propylene Glycol		Freezing Point	
By Mass	By Volume	°F	°C
0.0	0.0	32.0	0.0
10.0	9.6	26.1	-3.2
20.0	19.4	17.9	-7.8
30.0	29.4	6.7	-14.0
40.0	39.6	-8.1	-22.3
50.0	49.9	-28.9	-33.8
60.0	60.0	-54.9	-48.3

4 - glycol/water mixture chart

Fuel

- Only clean #1 or #2 diesel fuel or light heating oil is suitable for use in the system.
- The “central heat module” comes equipped with its own tank, so there are no fuel line hookups required.
- The fuel system utilizes a two-pipe system to ensure efficient fuel supply to the burner.

Contact your local fuel supplier to inform them of the requirements.

Primary “HTF” circulation lines

- If possible, position the primary circulation lines out of high traffic areas.
- If primary “HTF” circulation lines are required, connect the primary circulation lines to manifold “supply” and “return” quick couplers at the back of the central mobile enclosure. Quick couplers are attached to both ends of the primary circulation lines to enable quick coupling. This also allows the isolation of the primary lines while retaining the heat transfer fluid “HTF” in the lines. Plus... setup and dismantling of the circulation system is much quicker.

Burner Removal

To remove an existing **Riello model 40-F20 Diesel/Light Oil Burner**, use the following sequence:

- 1 Make certain that the power supply to the central heat module is disconnected.
- 2 Disconnect the electrical connection to the burner by disconnecting the #1, #2 and green/yellow wires attached to the control box (6-1) on the burner assembly. Slip the water tight connection (6-2) from the burner chassis, located in the bottom right corner of the burner assembly.
- 3 Disconnect the oil supply hose (7-1) and oil return hose (7-2) by unscrewing the fuel line connections on the side of the burner. The loose supply and return hose ends should be plugged and pushed aside out of the way inside the cabinet. Mark hoses for correct reconnection.
- 4 Remove the fuel pressure line (6-3) from burner fuel pump.
- 5 Remove 2 bolts (8-1) from top of burner tube bracket.
- 6 Pull burner toward you and away from the mounting bracket (8-2).

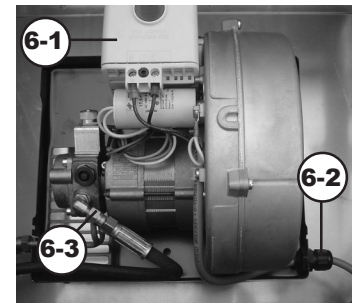

6 - Riello burner

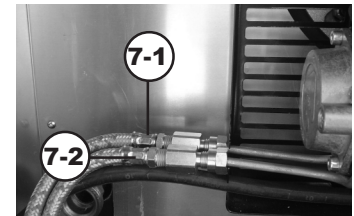

7 - oil supply and return lines

Burner Installation

To install a **Riello model 40-F20 Diesel/Light Oil Burner**:

- 1 Insert burner into the mounting bracket (8-2).
- 2 Install 2 bolts (8-1) at top of burner tube bracket.
- 3 Connect the oil supply hose (7-1) and oil return hose (7-2) by coupling them to the quick connections on the side of the burner. Insure hoses are attached to correct connectors
- 4 Connect the fuel pressure line (6-3) to the burner fuel pump.
- 5 Connect the electrical connection to the burner by connecting the #1, #2 and the green/yellow wires to the control box on the burner assembly (6-1). Once the wires have been reconnected, slip the water tight connection (6-2) into the burner chassis, located in the bottom right corner of the burner assembly.



8 - Riello burner tube and mounting bracket

Operation (CME)

Purging air from the “HTF” circulation system

- Verify that the primary circulation lines are connected to a distribution manifold.
- Complete the connection for one “heat exchanger loop” or “portable heat exchanger” This will close the circulation loop and allow circulation.
- Verify that the “supply” and “return” isolation valves (1-1) and the isolation valves at both ends of the primary circulation lines (hard connection to the manifold) are in the “open” position.
- The automatic air vent (2-1) valve cap (2-2) should not need adjustment. The valve cap should be opened 1 1/2 turns (counter clockwise) from fully closed to allow air escape from “HTF” system.
- Toggle the pump switch (3-1) to the “On”(up) position and run the pump. This will release the air from the system.
- Monitor the “heat transfer fluid sight glass” (4-1) and make sure that the heat transfer fluid level stays between 1/4 to 1/2 full at all times during this process.
- Note that there may be a certain amount of air in the system. “HTF” levels may change as air is displaced from the system. Add “HTF” fluid to maintain 1/4 to 1/2 levels when the fluid is cold.

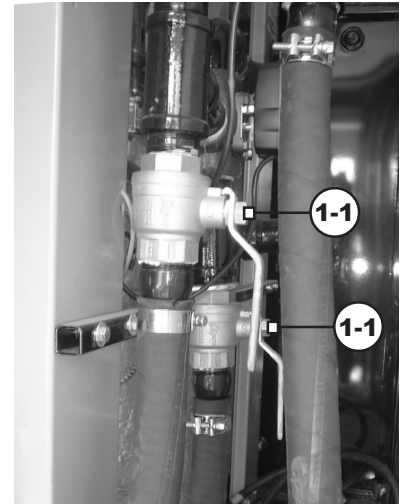

1 - “supply” & “return” isolation valve in the “open” position

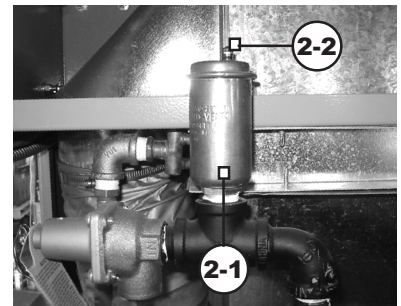

2 - automatic air vent



3 - pump, water heater & flow reverser switch

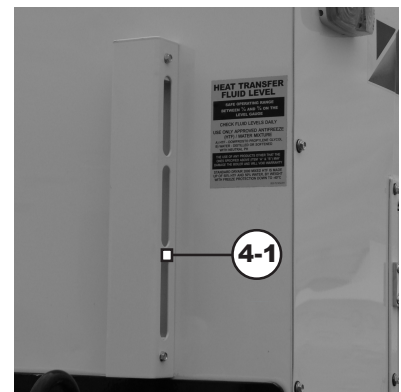

4 - heat transfer fluid sight glass

- When the air is eliminated, the “System Pressure” gauge (5-1) will hold at a steady reading of between 15 to 40 P.S.I.

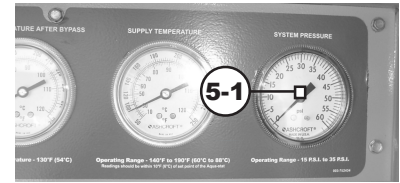

5 - system pressure gauge

Before firing the system

- Verify that the power supply is correct and that the electrical hook up is as specified in “Setup”.
- Verify that the water heater is being supplied with the same fuel type as indicated on the water heater data plate “*LIGHT OIL/DIESEL FUEL*”.
- Verify that the “supply” and “return” isolation valves (6-1) are closed.

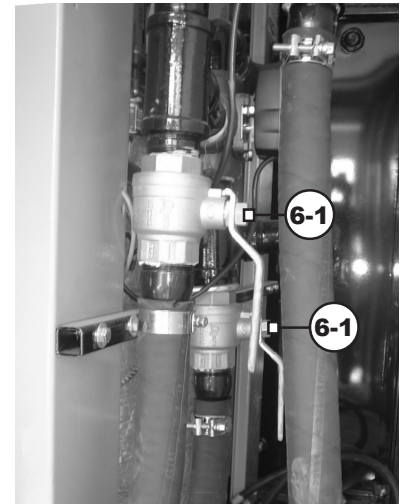

6 - “supply” & “return” isolation valve in the “closed” position

- Verify that the fuel line valves (7-1) & (8-1) are in the positions as shown, to the right.
- Verify that the heat transfer fluid level gauge (4-1) shows approximately 1/4 full.



7 - fuel return valve



8 - fuel supply valve and filter

Cold start procedure

This procedure must be completed if the ambient outdoor air temperature is lower than 50° F (10° C).

Consider initiating this process well in advance of firing the system.

In -30F (-34C) conditions, this process could take up to 6 hours.

- The system has a built-in, electric “cold start” fluid pre-heater which will heat the “heat transfer fluid” in the water heater heat exchanger.
- Confirm that the pump switch (9-1) and water heater switch (9-2) are in the “Off”(down) position.



9- 600 GTS control panel

- Position all four breakers (10-1) to the “on”(up) position. This will automatically energize the electric “cold start” circulation heater.
- Wait until the “supply temperature gauge” (11-1) reads between 140° F to 150° F (60° C to 65° C). The time required for the heat transfer fluid in the heat exchanger to reach this temperature will depend on the outdoor ambient air temperature.



10 - 600 GTS breaker box

- Toggle the pump switch (9-1) located on the control panel to the “On” (up) position. Once the pump is turned on, the “cold start” fluid pre-heater is automatically shut off.
- With the pump on and the “supply” and “return” isolation valves on the exterior of the heat module in the closed position, the “heat transfer fluid” will circulate through the heat module’s internal bypass system. This will supply warm “heat transfer fluid” to the combustion air and fuel preheat systems, which tempers combustion air and fuel for smooth burner start-up and operation.
- Continue circulating the “heat transfer fluid” within the heat module’s distribution system until the “combustion air gauge” (12-2) and the “fuel temperature gauge” (12-1) read approximately 60° F to 70° F (15° C to 21° C).

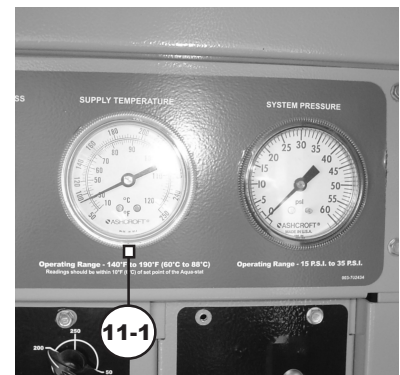

11 - supply temperature gauge

The time required for the combustion air and fuel to reach this temperature will again depend on the outdoor ambient air temperature.

- The burner is now ready to be fired. Proceed with the “Temperate Start Procedure”

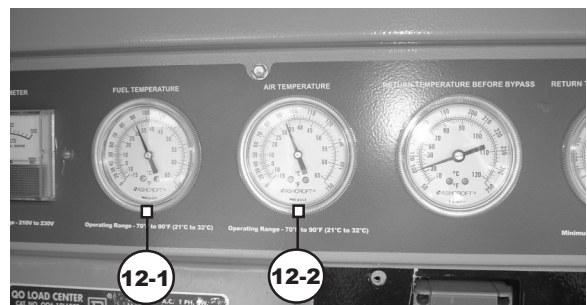

12 - combustion air & fuel temperature gauges

Temperate start procedure

You can proceed with this procedure when;

- 1) the ambient outdoor air temperature is above 50° F (10° C).
- 2) the “cold start procedure” has been completed.

Control settings

Low Flow Situations

Utilizing only one 80 or 200 portable heat exchanger or only one or two circulation line exchanger loops

- Water heater heat exchanger temperature overrun can be expected, therefore, initially set the aquastat (13-1) at 140°F (60°C) and the high limit switch (13-2) at 200° F (93° C).

Note: A single line heat exchanger loop may not have enough flow to activate the system flow switch. If this occurs, consider adding another loop of hose to increase flow and activate the system.

High Flow Situations

Utilizing two or more portable heat exchangers or three or more circulating line heat exchanger loops

- Set the aquastat (13-1) at 190°F (88°C) and the high limit switch (13-2) between 200°F - 210°F (93°C - 99° C).

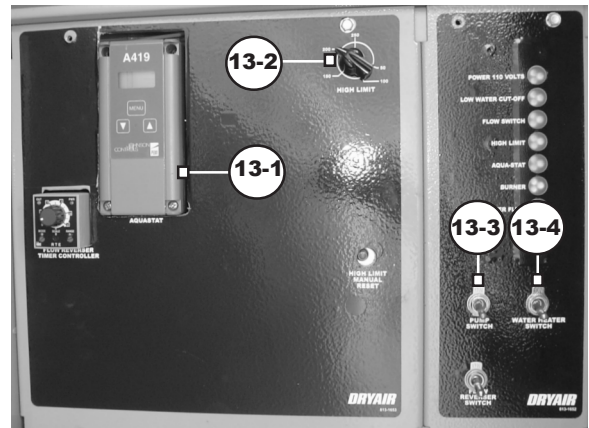

13 - 600 GTS control panel

Initiate firing

- Verify that the “Pump Switch” (13-3) is in the “On” (up) position.
- Toggle the water heater switch (13-4) to the “On” (up) position.
- The burner will proceed through its firing sequence.
- Once the burner is operating smoothly and the system pressure is steady (air has been eliminated from the system), monitor the “supply temperature” (14-1) until it is within 10° F of the aquastat temperature setting (14-1).
- Verify that only one “heat exchanger loop” or one “portable heat exchanger” is connected to the primary lines through the distribution manifold. This will close the loop and allow circulation from the “supply” side to the “return” side of the primary circulation line.
- Open fully the “supply” isolation valves (15-2).
- Open fully the “return” primary circulation line valve (15-3).
- Open the “return” isolation valve (15-4) to the “half open” position.
- The “half open” position will ensure a slow introduction of cold heat transfer fluid into the external circulation system and prevent a “cold-shock” of the system.

Note: do not close this valve more than the 1/2 closed position. The restricted flow may prevent the firing of the water heater.

- Incrementally open the “return” isolation valve (15-4) to a fully open position.
- Monitor the “Return temperature before bypass” gauge (16-1). Before fully connecting more “heat exchanger loops” or “portable heat exchangers”, this gauge must show a noticeable rise in temperature indicating the heat transfer fluid has made the full circuit. With “heat exchanger loops, this may take 10 minutes or more.
- Repeat the previous step until all “portable heat exchangers” or “heat exchanger loops” are connected and circulating.

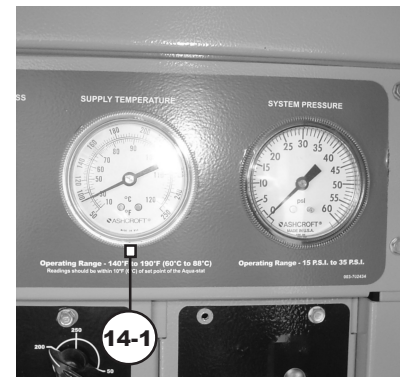

14 - supply temperature gauge

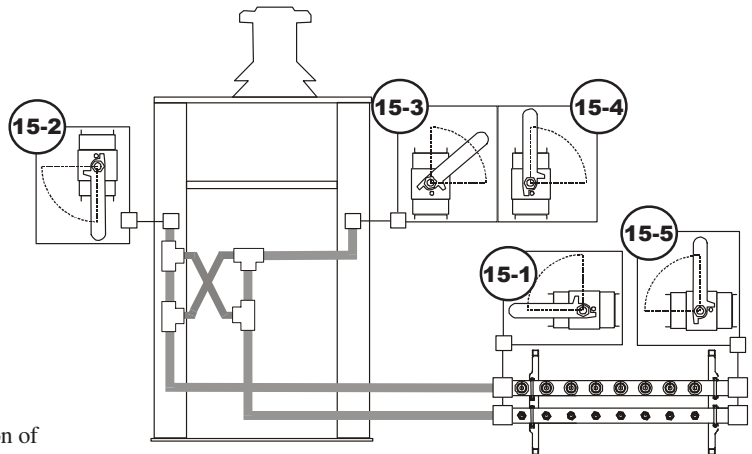

15 - circulation valve positions

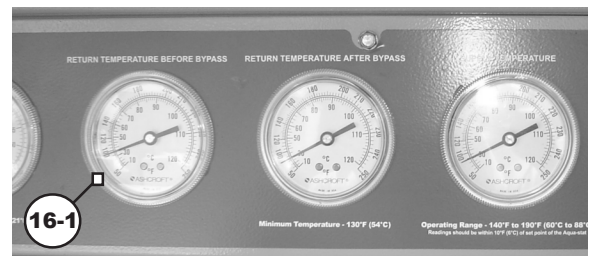

15 - return temperature before bypass gauge

Purging air from the fuel system

If the burner does not fire, the fuel system may have to be purged of air.

- Confirm that there is an adequate fuel supply.
- Toggle the water heater switch (17-2) to the “Off” (down) position.
- Open all manual valves in the fuel system. Set the 3-way fuel bypass valve (18-1) for full diversion to the tank (handle straight up and down). Set valve (18-2) to the “open” position.

- Confirm that the pump switch (17-1) is in the “On”(up) position.
- Toggle the water heater switch (17-2) to the “On” (up) position.
- Depress the reset button (19-1) . This will activate the fuel pump & burner firing sequence.
- When the fuel system is primed, the fuel pressure gauge (19-2) will show a steady reading and the water heater should attempt to ignite.

Note: The reset process can be tried up to six times at the most. If the water heater does not fire, see the accompanying “Water Heater Module - Service Manual” or the “Reillo Burners Installation Manual” for information and/or contact Technical Support.

- Once the water heater has ignited and the fuel pressure has stabilized, set the 3-way fuel bypass valve (18-3) to the two-pipe fuel system position (horizontal position)



17 - pump & water heater switch

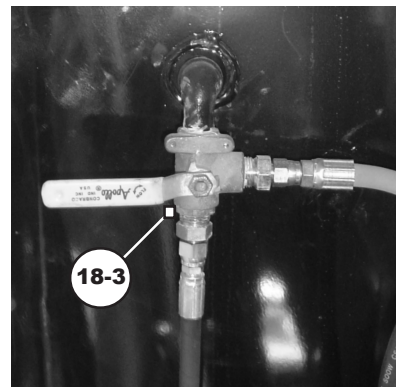
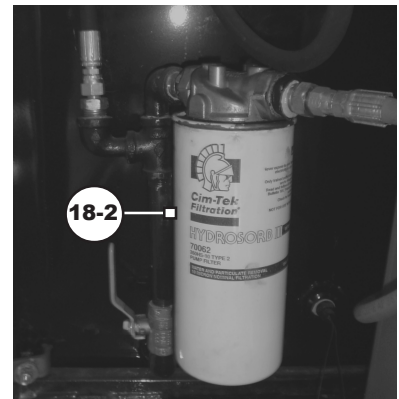
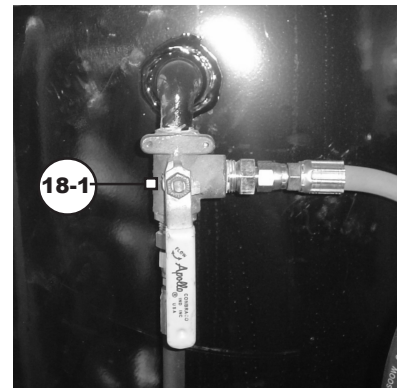

18 - fuel line valves in the fuel system

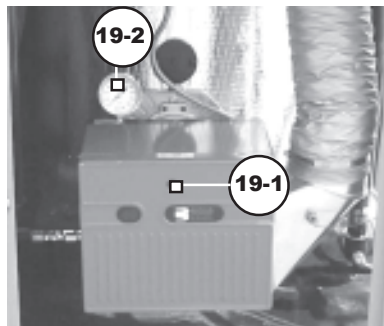

19 - Reillo burner and fuel pressure gauge

Adding “HTF” to system

Verify that the power supply is correct and the electrical hook up is as specified in “Setup”.

- Ensure all breakers are in the “On” position.
- Remove fill/drain hose plug (20-2) from the Fill/Drain hose (20-1).
- Submerge the fill/drain hose into the bottom of the barrel/pail or jug or pre-mixed “HTF” (See “Setup” for heat transfer fluid specifications).
- Turn the supply ball valve (21-1) to the “Closed” position.
- Turn the fill/drain ball valve (22-2) to the “Open” position.
- Toggle the pump switch (23-2) to the “On” (up) position.
- Once the pump switch is in the “On” position, the pump will comense to suck the “HTF” into the system. By watching the glycol level gauge (24-1), continue to fill the system until the glycol level gauge shown 1/2 full.

Caution: Caution must be taken when approaching the 1/2 full mark as it could take 2-3 seconds to register the actual level once pumping has ceased.

- In the case of an overful situation, do the following:
 - Toggle the pump switch (23-1) to the “Off” (down) position
 - Verify that the fill/drain ball valve (22-2) is in the “Open” position
 - Turn the supply ball valve (21-2) to the “Open” position. Gravity will immediately drain the glycol out of the system through the fill/drain hose. The fill/drain hose should be submerged into a barrel/pail or jug with sufficient room for the “HTF”
 - Once the desired amount of “HTF” has been attained and the glycol level gauge is showing half full, turn the supply ball valve (21-1) to the “closed” position and continue with the follow procedures
- Turn the fill/drain ball valve (22-2) to the “Closed” position.
- Toggle the pump switch (23-1) to the “Off” (down) position.
- Turn the supply ball valve (21-2) back to the “Open” position.

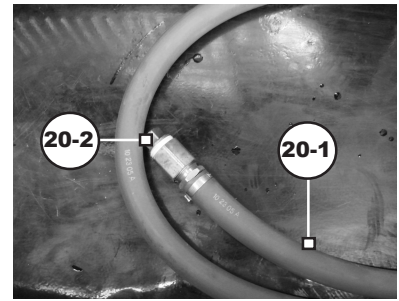

20 - fill/drain hose and plug

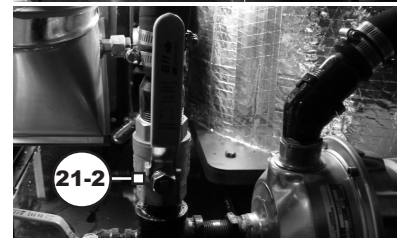

21 - supply ball valve (open & closed)

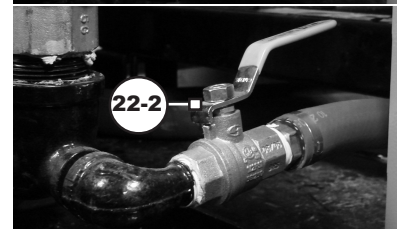
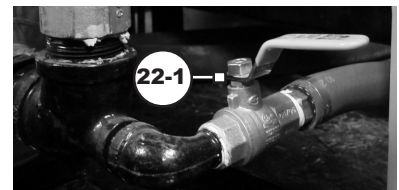

22 - fill/drain ball valve (open & closed)



24 - glycol level gauge

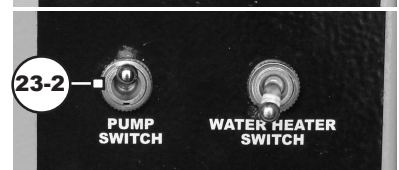
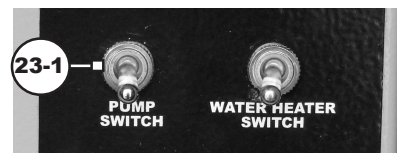

23 - 600 GTS control panel- pump switch

Setup/Operation (HR2250)

Danger! It is very important that you read and understand this section before operating the hose reel! Failure to follow the procedures and cautions in this manual could lead to injury or possible death!

Manual Controls

The Hose Reel has a manual method of controlling the spool rotation “UNLOAD/LOAD” and a general ON/OFF power switch.

Caution! When NOT operating the reel, put the reel speed toggle switch (1-1) in the “Off” position to prevent accidental activation and possible injury. When the hose reel is to be left unsupervised, the power cord should be unplugged from the power supply.

Reel Power

Power is present when the power switch (1-1) is in the “ON” position. By connecting the foot switch you can load or unload hose by depressing the foot switch (1-2) which is momentary (will only operate when depressed).

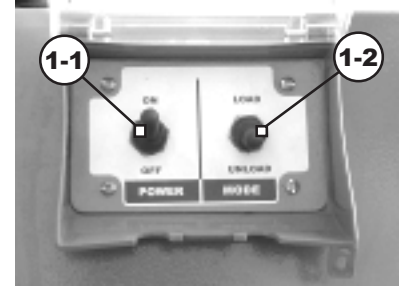

1 - power & mode toggle switches

Reel Direction Modes

Mode 1 - UNLOAD

Mode 2 - LOAD

Caution! Take care not to allow your hands, feet or clothing to become trapped by any of the reel’s moving mechanisms.

Mode 1 - “UNLOAD”

- The UNLOAD mode is achieved with the mode toggle switch (1-2) in the UNLOAD position.
- The foot switch (2-1) is momentary and will only operate when it is depressed.

Mode 2 - “LOAD”

- The LOAD mode is achieved with the mode toggle switch (1-2) in the LOAD position.
- The foot switch (2-1) is momentary and will only operate when it is depressed.
- The hose must be directed manually into position on the hose reel.

Note: To eliminate initial clutch slippage when loading hose, one loop of hose should be left slack prior to initiating hose loading.

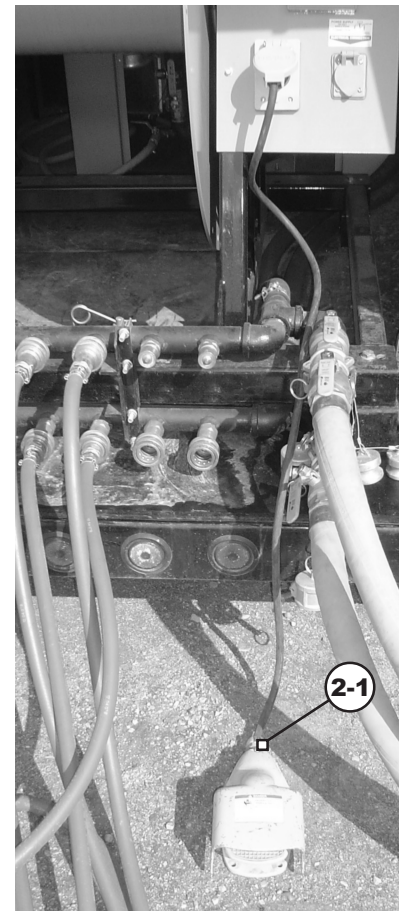

2 - Foot switch

Mechanical Drive Components

Access to the internal mechanical drive components is through the access door. This door must be removed.

Electric Motor

- The electric motor used to drive the reel is manufactured by Marathon Electric.
- No regular maintenance is required.
- Low temperature manual reset thermal protector.
- Totally enclosed and fully gasketed construction for dirty environments.
- Make sure that, during operation or storage, the motor is not in prolonged contact with moisture.
- Refer to the chart “Table 1- Electric motor features & data”, below for motor data.



1 - Access door

PRODUCT FEATURE - ENCLOSED HIGH TORQUE MOTOR			
Model Number:	56C17F5913	Phase:	1
HP:	3/4	Mult. Symb.	F1
RPM:	1725	F.L. Amps	11/5.4-5.5
Volts:	115/208-230	Wght. Lbs.	30
Frame:	56C	"C" Dim.	12.32
Overload:	MANUAL	Foot Notes:	2
Mounting:	C-FACE	S.F.:	1.15

Table 1 - Electric motor features & data

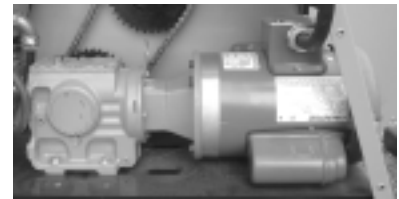

2 - Marathon electric motor

Gear Box

Gear box specifications

- HUB CITY - Poweratio 2000, Model HW2042ER (Assy #: 0251-00534)
- Modified helical worm reducer
- 102:1 gear reduction
- 5/8" input shaft size
- 1" output shaft

CAUTION

Do not operate the unit without ensuring it contains the correct amount of oil. Do not overfill or underfill with oil. Injury to personnel, unit, or other equipment may result.

Oil should be changed with greater frequency if unit is used in severe environment (dusty or high humidity).

WARNING

Oil, housing, and other components can reach high temperatures during operation, and can cause severe burns. Use extreme care when removing lubrication plugs and vents while servicing the unit.

See “Maintenance - Gear Box” section of the operators manual for Hub City Gear Box oil filling procedures, service & maintenance.

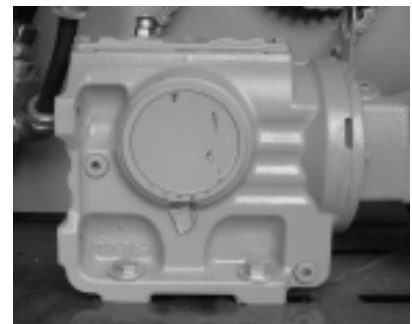

3 - Hub City gear box

Torque Limiter Clutch

- The Torque limiter protects the drive line from damage due to overload conditions. The driven center member slips on non-asbestos friction discs during overload situations in the drive line.
- Torque Ratings
GLI Model 350 w/ two springs
 - minimum: 60 lb.-ft.
 - maximum: 190 lb.-ft.

Please note that the torque ratings are estimates.

Actual torque capacity may vary significantly depending on many factors. Field conditions such as oil, humidity, water and temperature as well as the frequency and duration of slippage all affect torque capacity.

Although the torque limiter clutch is factory set at Dryair, periodic adjustment may be required. It is recommended the torque setting of the clutch be checked twice per season (see "Maintenance" section). With prolonged use, the two friction disks, located on either side of the A-plate sprocket, will eventually show wear.

- It is important that the torque limiter clutch is adjusted properly. If the clutch slips too easily, the spool will take too long to stop and hose will pile up on the reel. If the clutch does not slip at all, damage will occur to the drive system.

Note: A visual check may be required to confirm whether it is the clutch that is slipping or the motor.

See "Maintenance - Torque limiter adjustment" section of the operators manual for Torque Adjustment & Run-In Procedure.

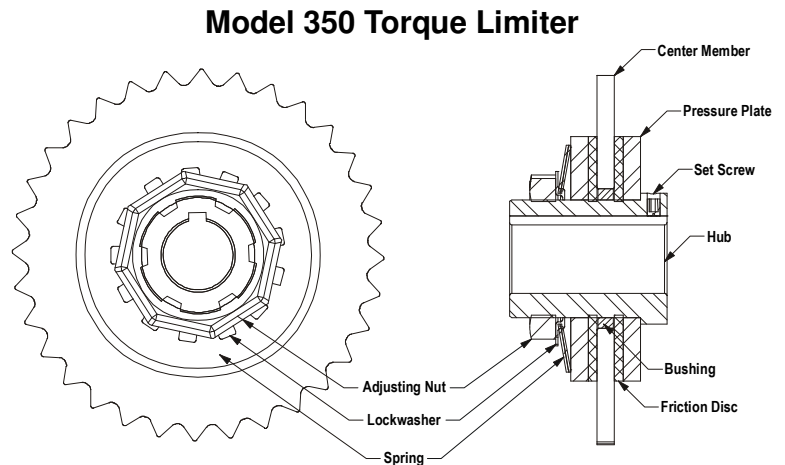

Troubleshooting (CME)

- There are 6 green lights on the control panel, which indicate the status of a sequence of functions while the unit is running.
- Aquastat and burner light go off and on as the burner cycles.
- When the burner is on, all green lights should be on. With the burner on, any light which is not on should be considered burned out.
- Troubleshoot power issues at the control panel control strip. Remove control panel to expose terminal strip.

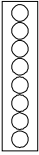

No power at outgoing side of water heater toggle switch

Check for 120 volt power between letter N and #1 on the terminal strip. If no power check the following:

- a) Check that the circuit breaker for the water heater has not been switched off.
- b) Check that the toggle switch for the water heater has not been turned off.
- c) Check for power in and out of breaker and toggle switch.
- d) Check that correct power supply has been connected to the unit. Investigate power source and be certain that the power characteristics are correct. (115/230 volt, 30 amp, single phase, 4-conductor, 0'-100' - 10 AWG, over 100' - 8 AWG)

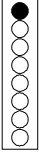

No power at Terminal #4 on low water cutoff

Check for 120 volt power between letter N and #2 on the terminal strip. If no power check the following:

- a) Low water situation. Check fluid level in tank and add if necessary.
- b) Check fuse in low water cut off. Replace if required.

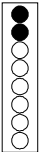

No power at flow switch

Check for 120 volt power between letter N and #3 on the terminal strip. If no power check the following:

- a) Pump not running. - Check pump breaker and toggle switch on control panel. - Check for 230 volts at pump motor. If correct power is confirmed at motor, but pump won't run, refer to "G&L Pumps, Installation, Operation & Maintenance Instructions, 11-Troubleshooting Chart" for more in-depth troubleshooting.
- b) Inadequate flow.
 - Check that all valves are open in the fluid-transfer loop. - Filter screen may be plugged. Use flush hose/valve attachment into a bucket, while pump is running, for a quick Y-strainer flush (see Y-strainer flush in Maintenance section of Operators Manual). Eventually the system may have to be drained and the filter screen removed and cleaned by hand (see Y-strainer screen in Maintenance section of Operators Manual). - Check that pressure bypass valve is open, if fluid-receiving units are closed off.
 - When performing "ground thaw" or "concrete cure" application, the use of only one "heat exchanger loop" may result in inadequate flow. Utilizing at least two "heat exchange loops" will provide adequate flow... or a short bypass loop can also be incorporated to correct this situation.
 - Air present in the circulation system. Air in the system can cause cavitation in the pump and pressure loss. Refer to "Operation, Purging air from the system" for air purging instructions.
 - Supply temperature overrun causing vaporization (steam) & pump pressure to be lost. Cavitation will occur in the "water heater heat exchanger" causing a noticeable bubbling, popping sound. Check the "overflow outlet" to confirm presence of fluid vapor. If vaporization is occurring, the "aquastat" setting is set too high. Reset the "aquastat" to a lower temperature (10°F increments) and allow cool-down. When the "heat transfer fluid" cools down, the system will regain pump pressure. Allow the burner to cycle back on and observe to ensure that the vaporization situation does not reoccur. If it does reoccur, reset the "aquastat" to a lower temperature until the problem is rectified.

Note: This situation will occur more often in a "low flow" situation (refer to Operation, Temperate Start Procedure, Control Settings).

- c) Defective flow switch. - If a) and b) check out good, the flow switch will need to be re-calibrated, or replaced.

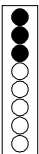

No power at aquastat

Check for 120 volt power between letter N and #6 on terminal strip. If no power check the following:

- a) Check setting on aquastat.
- b) Check sensor and verify that it is intact in it's well.
- c) If a) and b) check out good, replace both aquastat and sensor.

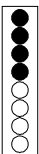

No power at outgoing side of high limit switches.

Check for 120 volt power between letter N and #5 on the terminal strip. If no power check the following:

- a) Manual reset high limit reset button tripped.
- b) Check settings of switches. The automatic high limit should be set 10°F higher than the set point of the aquastat, and the manual reset high limit should be set 10°F higher than the automatic high limit switch.
- c) Determine which high limit switch is defective and replace.

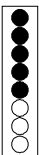

No power at burner

Check for 120 volt power between letter N and #7 on the terminal strip. If power check the following:

- a) Check for 120 volt power at the burner. If power present there is a fault in the burner. See the enclosed Riello burner information to trouble shoot the burner system.

Maintenance

Central Heating Module

Daily checklist

A daily inspection of the water heater cabinet should be performed with attention paid to the following:

Check for strong odor of gas

- If a leak or the odor of fuel is noticed, immediately turn off all power switches and the main fuel supply to the water heater cabinet.
- Ventilate the water heater cabinet.
- Find and correct the leak before turning on any power or trying to relight the water heater.

Check heat transfer fluid “HTF” level every day

- Maintain between $\frac{1}{4}$ and $\frac{3}{4}$ on the heat transfer level gauge when fluid is hot
- Top up as necessary
- For “HTF” specifications, see “Setup, Heat Transfer Fluid “HTF”, Fluid Specifications.
- For “HTF” handling precautions, refer to the “Safety Concerns, Material Safety Data Sheet”.
- If loss of fluid is excessive, check for leaks at all fittings and connections in the water heater cabinet as well as the fluid circulation system.

Check the supply temperature gauge

- Verify that the supply temperature gauge is within 10°F of the aquastat setting.

Seasonal checklist

Fuel (water block / particulate) filter

- The water block/particulate filter should be changed every heating season or as required.

Hoses

- Periodically check all hoses for damage due to aging, elevated temperatures, over-torqued hose clamps, abrasion and weathering.
- Replace damaged hoses as required.
- Seasonally check hose clamp torque and adjust accordingly.

Water heater heat exchanger

- Keep the flues in the water heater clean. Because soot is a nonconductor of heat, a dirty water heater requires more oil to heat a structure than a clean one. Water heaters can corrode on the fireside. This results from corrosive substances in the fuel and can be difficult to control. Some fuel oils contain substances, which cause fireside corrosion. Sulphur, vanadium and sodium are among the materials that may contribute to this problem. The probability of trouble from this source depends to a large degree on the amount of sulphur in the fuel and on the care used in cleaning the fireside heating surfaces. This is particularly true when preparing a boiler for a period of idleness. Preventing this problem also depends on keeping the boiler heating surfaces dry when a boiler is out of service.
- The person responsible for water heater maintenance should be certain that the fireside surfaces of the water heaters in his care are thoroughly cleaned at the end of the firing season. He should also observe the fireside surfaces during the firing season and if signs of corrosion are discovered, a reputable consultant should be contacted.
- The flue pipe and chimney cap should be taken off once a year and thoroughly cleaned of all soot.

Heat exchanger cleaning procedure

- Remove the burner from the water heater (1-1)
- Remove the plate (1-2) from the bottom of the water heater.
- Remove the refractory board (1-3) from the water heater by reaching into the burner hole and lightly tapping the board with your hand until it drops down.
- Remove the flue collar (1-4) to expose the burner tubes (1-5).
- Remove all flue baffles (1-6).
- Clean burner tubes (1-5) with a steel round brush or a rag on a piece of rod.
- Vacuum all debris.

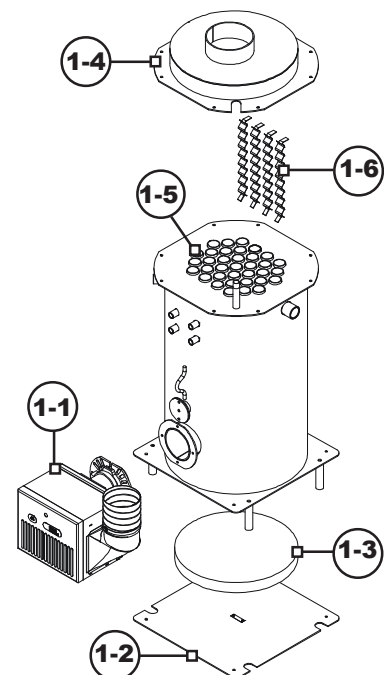

1 - heat exchanger breakdown

Heat transfer fluid “HTF”

- A clean, properly maintained hot water system should not be drained unless: there is possibility of freezing, the boiler has accumulated a considerable amount of sludge or dirt on the water side, or draining is necessary to permit repairs. Very little sludge should accumulate in a water heater where little make-up water is added and where an appropriate water heater water treatment is maintained at proper strength.
- The Heat transfer fluid should be tested from year to year for freeze protection and should be strong enough for your area. The heat transfer fluid should be checked with a refractometer. Check the glycol/water mixture chart (see “Setup, Heat transfer fluid HTF”) for mixing ratios.
- The “pH level” of the heat transfer fluid requires an annual check to see if the pH level is neutral. The pH level should be at #7. This should be checked with a pH instrument.

See “Setup, Heat transfer fluid HTF, Heat transfer fluid specifications” for complete heat transfer fluid specifications

Burner

- For burner seasonal maintenance, see the “Service Manual”.

“Y”strainer

“Y”strainer flush

- The “Y” strainer (2-1) requires regular maintenance every time system is set up or 1000 hours of operation.
 - Remove the end plug from the end of the strainer outlet valve
 - Position a 5-gallon container at the outlet valve.
 - With the pump running, crack the strainer valve a number of times. A quick on/off action of the valve will provide the short bursts required to backwash and clean the strainer. The removal of a couple of gallons of heat transfer fluid should be adequate.

NOTE: Be certain not to run the reservoir empty, as this would allow air to enter the system.

- The extracted heat transfer fluid can be reused. Before pouring the fluid back into the reservoir, the fluid must be filtered to remove impurities. Filtering the fluid through a cotton cloth or paper is adequate.

“Y”strainer screen cleaning procedure

- Clean the screen (3-1) located inside the “Y” strainer prior to every installation.
 - Remove the end plug from the end of the strainer outlet valve
 - Position a container at the outlet valve. A couple of 5 gallon containers should do.
 - With the pump “off”, drain off the “HTF” until there is no more flow.
 - Remove the top of the “Y” strainer and extract the screen (3-1)
 - The screen should be cleaned using warm water and a soft bristled brush.
 - Reassemble and ensure that all fittings are tight
 - The extracted heat transfer fluid can be reused.
 - Air will have to purged from the system. Refer to “Operation, Purging air from the “HTF” circulation system” for instructions.



2 - back washing Y-strainer

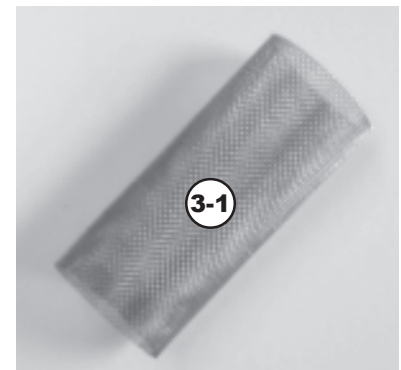

3 - Y-strainer screen

HR2250

Danger! It is very important that you read and understand this section before operating the hose reel! Failure to follow the procedures and cautions in this manual could lead to injury or possible death!

Precautions

Electric shock will result in death or serious injury.

- The user is responsible for conforming to all applicable code requirements with respect to grounding all equipment.
- DO NOT touch unshielded components or terminal strip screw connections with voltage present.
- Install and close all covers before applying power or starting and stopping the hose reel.
- Before servicing:
 - Disconnect all power.
 - Place a “DO NOT TURN ON” label on the drive controller disconnect.
 - Lock the disconnect in the open position.
- Disconnect all power including external control power that may be present servicing the drive controller. WAIT 15 MINUTES for the DC bus capacitors to discharge.

Manual Resets

Ground Fault

If a fault occurs due to a prolonged overload, overvoltage, undervoltage or phase failure, the control must be manually restarted. The control can be restarted by:

- 1) Disconnect AC power and wait for at least 30 seconds for drive controller to power down.
- 2) Reconnect the AC power. This will re-initiate the factory default settings.

Electric Motor

- The electric motor used to drive the reel is a Marathon.
- No regular maintenance is required.
- Make sure that the motor is not in prolonged contact with moisture during operation or storage.

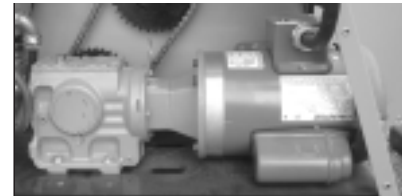

4 - Marathon electric motor

Torque limiter adjustment

- Although the torque limiter clutch is factory (Dryair) set, periodic adjustment may be required. It is recommended the torque setting of the clutch be checked twice a season. With prolonged use, the two friction disks, located on either side of the A-plate sprocket, will eventually show wear.
- It is important that the torque limiter clutch is adjusted properly. If the clutch slips too easily, the spool will take too long to stop and hose will pile up on the reel. If the clutch does not slip at all, the protection on the Altivar 11 drive will take over and the spool will again take too long to stop.

Note: A visual check may be required to confirm whether it is the clutch that is slipping or whether it is the Altivar 11 drive that is automatically adjusting in an overload situation.

- Check that the clutch is adjusted properly with the following procedure:

Physical check

- With no power being applied to the reel, grip the edge of the spool plate and apply full upward force, making sure that you are lifting with your legs and not your back.
- You should be able to cause the clutch to just slip with full lifting force.
- If the clutch does not slip or slips too easily, refer to the “torque adjust procedure”, below.

Torque adjust procedure

- Insure that the adjusting nut is in a finger tight position.
- If the adjustment nut is tighter than finger tight, loosen and complete previous step.
- Match mark the adjusting nut with the hub. Using a torque wrench tighten the adjusting nut to 90ft*lb.

After the break-away torque is set, bend the tabs of the lock washer over the hex flats of the adjusting nut.

Note: The torque limiter clutch nut requires a reasonable amount of force to adjust. Use a torque wrench that provides you with at least 18” of leverage.

Run-in procedure

- If the torque has been taken apart and reassembled or friction disks have been changed, it is recommended that the clutch be “run in” by “slipping” the center member (sprocket).
- Insure that the adjusting nut is in a finger tight position.
- Match mark the adjusting nut and hub. Advance the adjusting nut ¼ turn from finger tight.
- Slip the torque limiter sprocket for 8 minutes at full RPM.
- Refer back to the “Torque adjust procedure” for final readjustment.

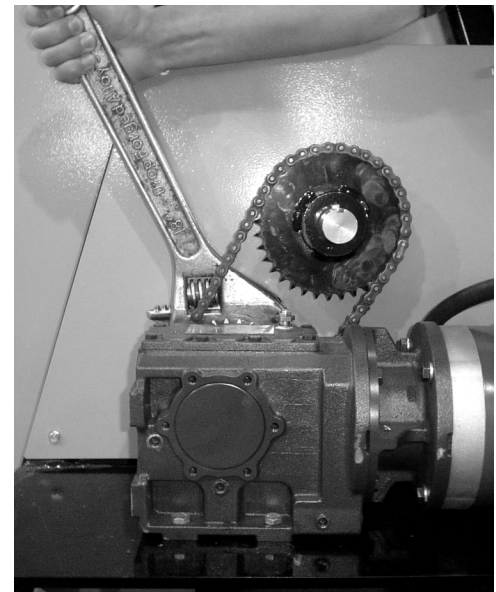

5 - torque limiter adjustment

Model 350 Torque Limiter

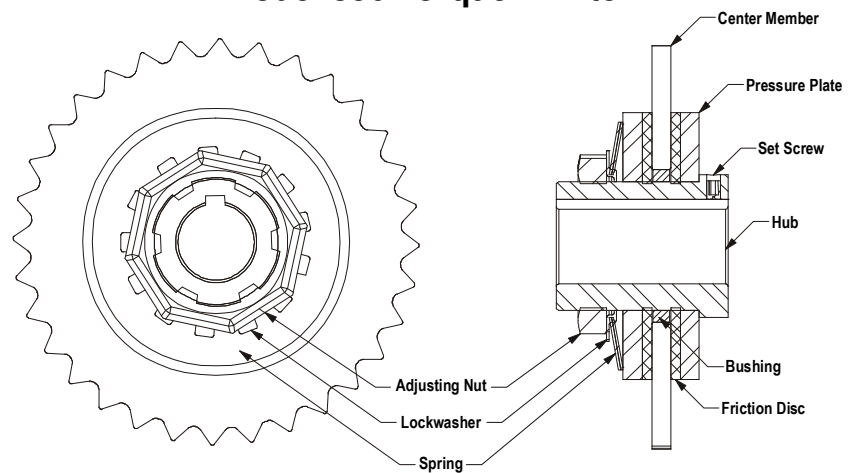

6 - torque limiter assembly

Gear Box

Maintenance & Operation

WARNING

Oil, housing, and other components can reach high temperatures during operation, and can cause severe burns. Use extreme care when removing lubrication plugs and vents while servicing the unit.

- Do not operate the unit without making sure it contains the correct amount of oil. Do not overfill or underfill with oil, or injury to personnel, unit, or other equipment may result.
- For proper operation in subzero conditions, it is mandatory that the following oil be used:
“Spartan EP 320 industrial gear oil”
...any other gear oil will void warranty!

Oil Filling Procedure

- Remove Fill (#-1) and Breather Plug (#-2).
- Clean threads on the removed plugs and the plug holes with degreaser.
- Fill gear box with the recommended lubricant (see above) to a level near the center line of the uppermost horizontal shaft or until lubricant comes out of the oil level plug hole.
- Install plugs secure in gear case.

Break-In Period

After the first 100 hours of operation, drain out initial oil, flush out the gear case with an approved non-flammable, non-toxic solvent, such as Whitmore’s Flushing Oil (#06802030) or Medallion Flushing Oil Kosher (#06812010), and refill. Thereafter, oil should be changed at least every 2500 operating hours or every 6 months - whichever occurs first.

Note: Oil should be changed with greater frequency if unit is used in severe environments (dust or high humidity).

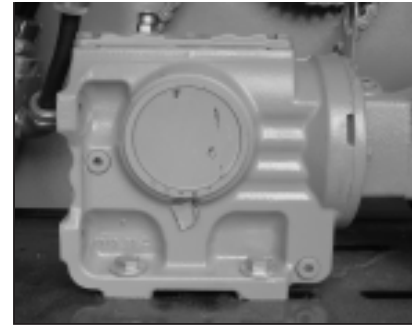

7 - gear box

Appendum

Important Certification & Operational Information Decals

Non-pressure vessel decal

ATTENTION!

This Unit is Certified to CSA & UL Standards for use as a NON-PRESSURE VESSEL

- The unit includes an **open atmospherically vented** expansion tank.
- The expansion tank is integrally connected to the heat-exchange section of the water heater by means of a permanently open line (no valves).
- The heat exchange section connects to the inlet side of the circulating pump and therefore, only neutral atmospheric pressure is present within the heat exchange section.

1 - non-pressure vessel decal

Certification & Heater Specifications



P.O Box 126
400 Service Road
St. Brieux, SK
Canada
S0K 3V0



MADE IN CANADA

DRYAIR Model:	600 GTS	Reference:	
Serial No.:		Prod. Sched.:	

Volts:	115 V	Model:	Riello 40-F20
Phase:	1	Fuel:	#2 Heating Oil #1 Heating Oil
Hz:	60 HZ	Calorific Value:	140,000 BTU / US Gal. 136,000 BTU / US Gal.
Max. Ampacity	15 A	Output:	508,564 BTUH 500,058 BTUH
Control Voltage	115 V	Fuel Input:	4.43 US GPH
		Pump Pressure:	160 P.S.I.

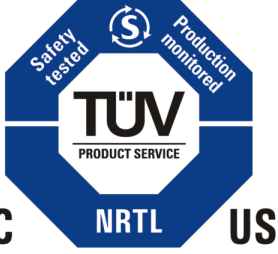

C NRTL US

COMPLIES TO:
 UL 508A/CAN CSA C22.2 No.14
 UL 726/CAN CSA C22.2 No.3
 CAN/CSA C22.2 No. B140.7.2
 CAN/CSA C22.2 No.B139
 ANSI/NFPA 31

Clearances:

Sides	24" (61cm)minimum
Flue	36" (91cm)minimum
Floor	0" (0cm) non-combustible

003-900784-R1

2 - TUV-SUD certification label 600 GTS



P.O Box 126
400 Service Road
St. Brieux, SK
Canada
S0K 3V0



MADE IN CANADA

DRYAIR Model:	600 GTS (sub-40)	Reference:	
Serial No.:		Prod. Sched.:	

Main Power		Oil Burner	
Volts:	230 V (2L,N,G)	Model:	Riello 40-F20
Phase:	1	Fuel:	#2 Heating Oil #1 Heating Oil
Hz:	60 HZ	Calorific Value:	140,000 BTU / US Gal. 136,000 BTU / US Gal.
Max. Ampacity	30 A	Output:	508,564 BTUH 500,058 BTUH
Control Voltage	115 V	Fuel Input:	4.43 US GPH
		Pump Pressure:	160 P.S.I.

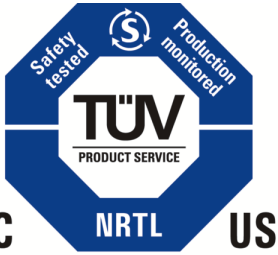

C NRTL US

COMPLIES TO:
 UL 508A/CAN CSA C22.2 No.14
 UL 726/CAN CSA C22.2 No.3
 CAN/CSA C22.2 No. B140.7.2
 CAN/CSA C22.2 No.B139
 ANSI/NFPA 31

Clearances:

Sides	24" (61cm)minimum
Flue	36" (91cm)minimum
Floor	0" (0cm) non-combustible

003-900785-R2

3 - TUV-SUD certification label 600 GTS (sub-40)

Electrical schematics

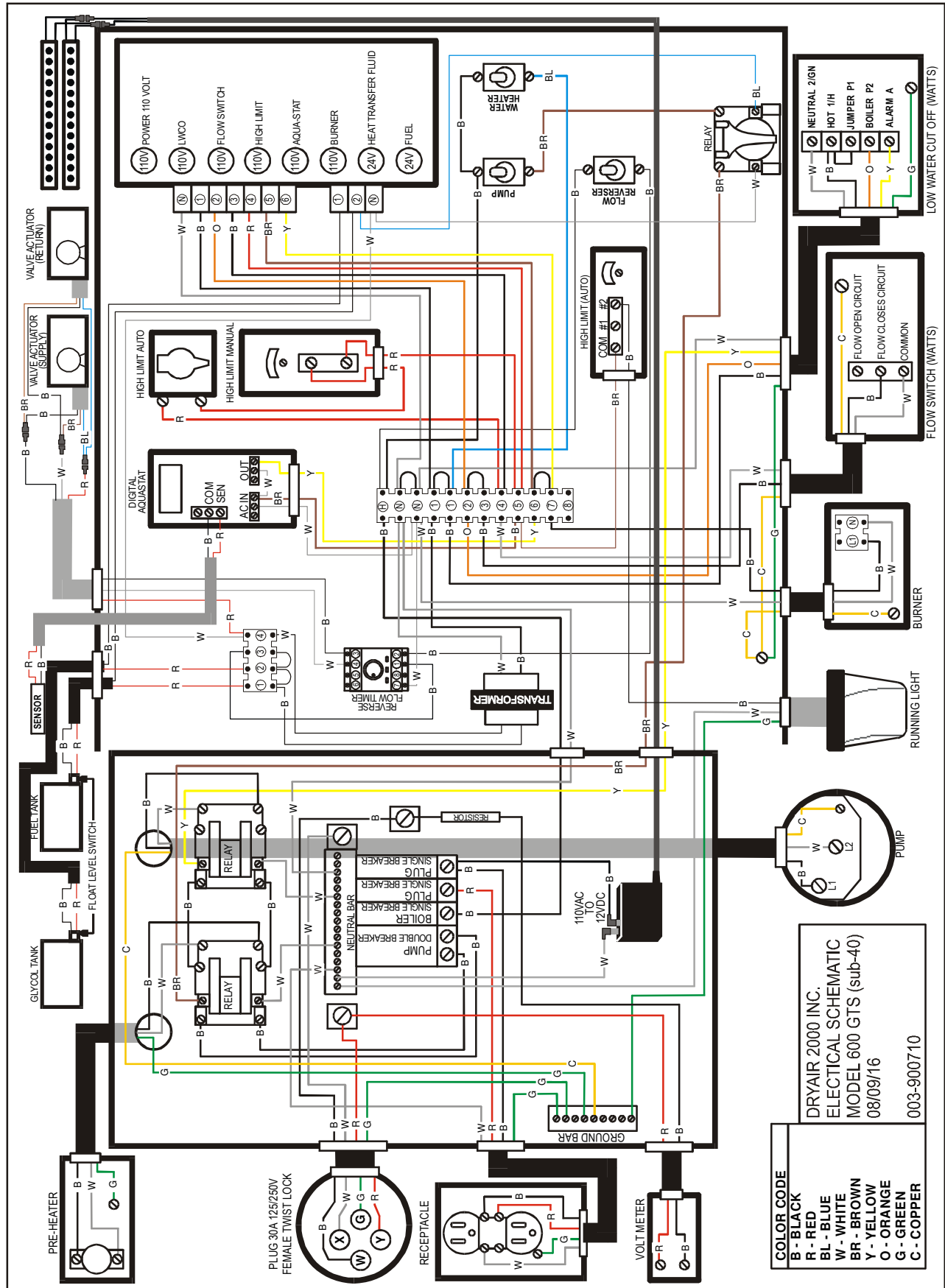

3 - 600 GTS (sub-40)electrical schematic

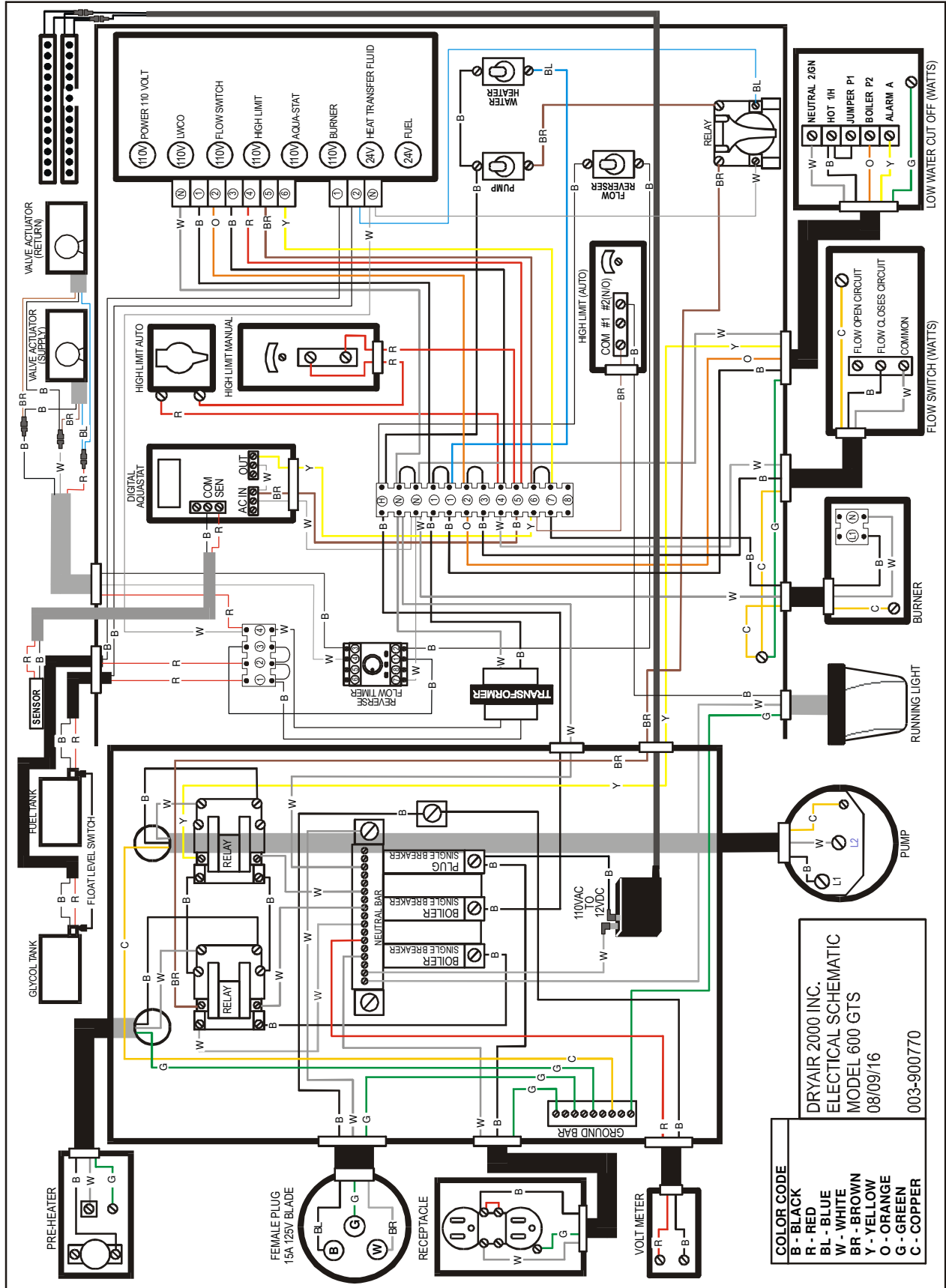

3 - 600 GTS electric ... schematic

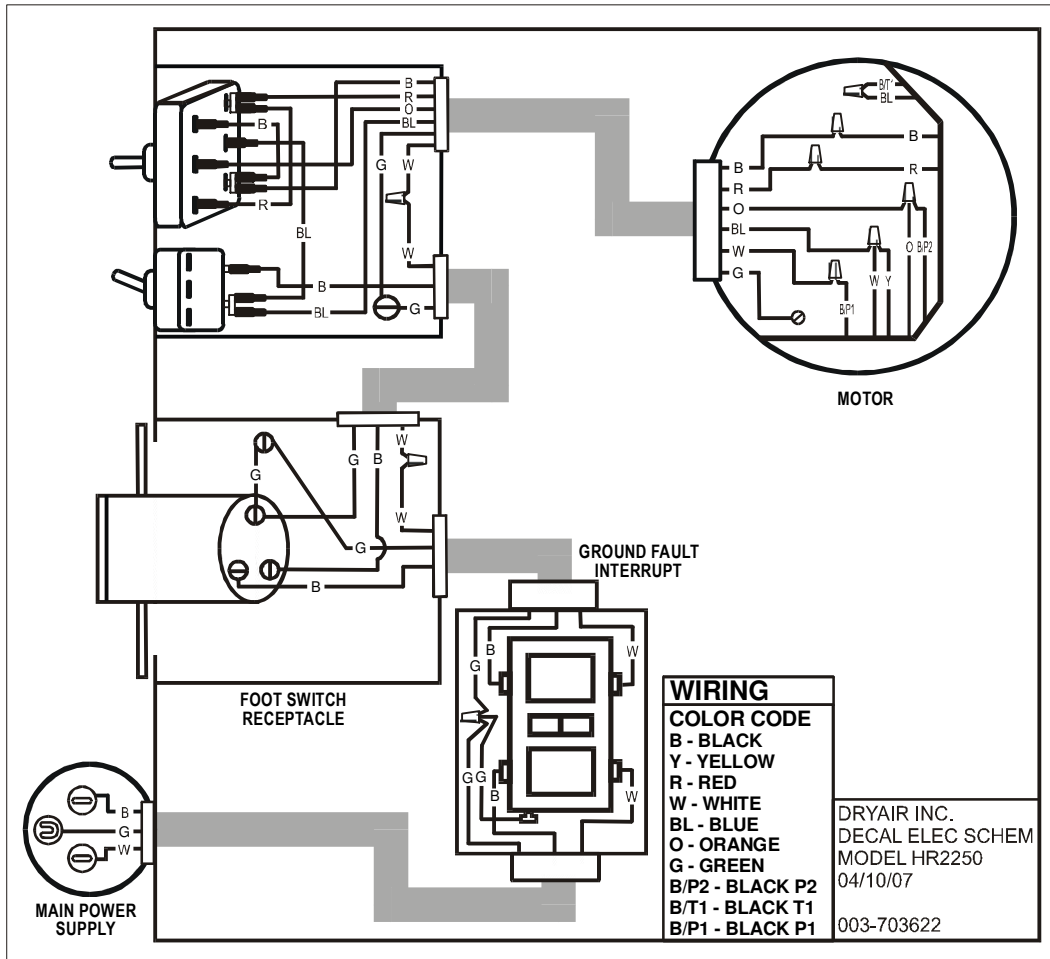

3 - HR2250 electrical schematic

002-901214 CABLE TRLR 12GAx6WIRE 10GAX1WIRE MULTI-STRD

WHITE - GROUND
 BLACK - BATTERY CHARGE
 YELLOW - ACCESSORY
 RED - LEFT SIGNAL
 BROWN - RIGHT SIGNAL
 BLUE - BRAKES
 GREEN - RUNNING LIGHTS

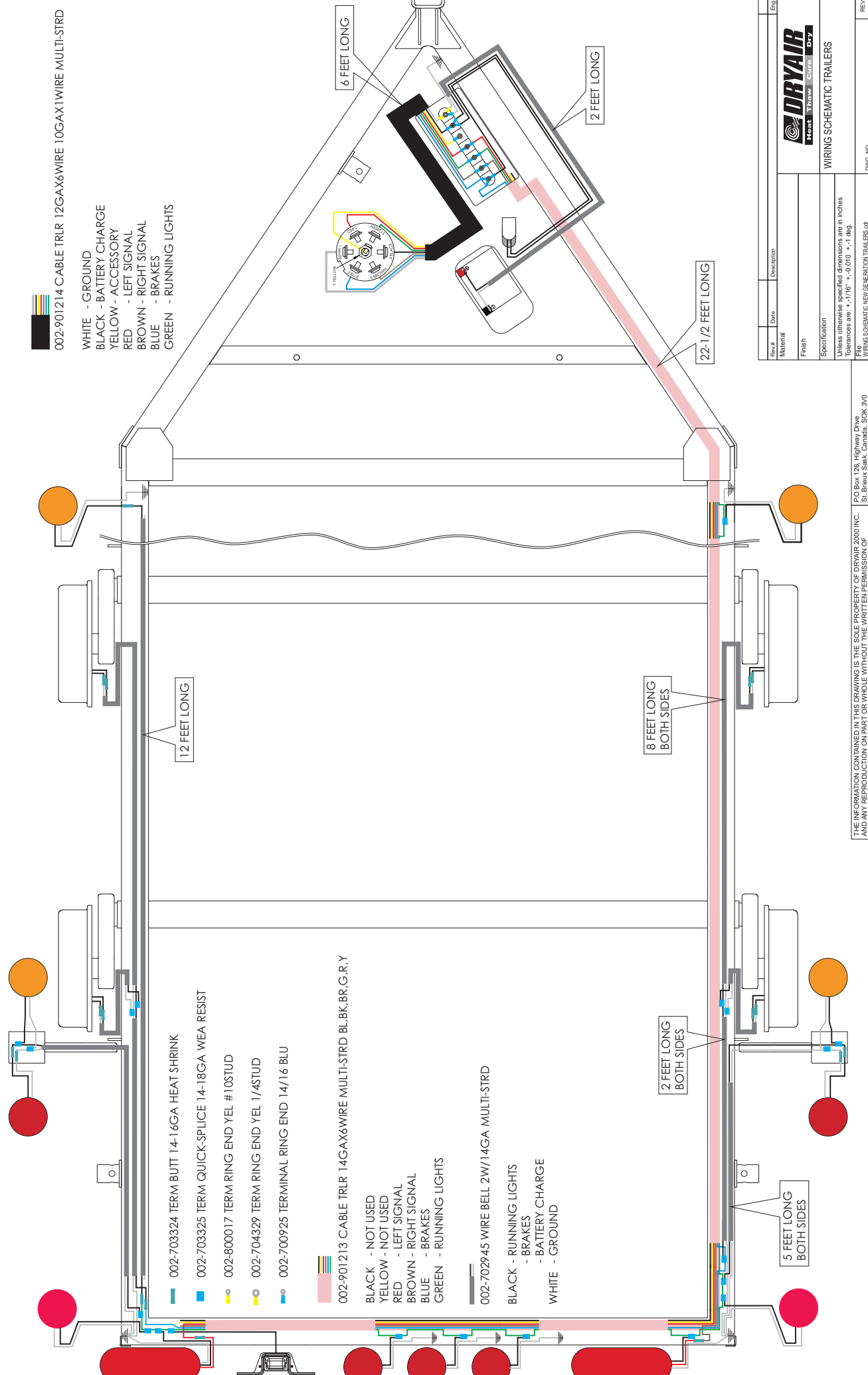

002-703324 TERM BUTT 14-16GA HEAT SHRINK
 002-703325 TERM QUICK-SPLICE 14-18GA WEA RESIST
 002-800017 TERM RING END YEL #10STUD
 002-704329 TERM RING END YEL 1/4STUD
 002-700925 TERMINAL RING END 14/16 BLU

002-901213 CABLE TRLR 14GAx6WIRE MULTI-STRD BL.BK.BR.G.R.Y

BLACK - NOT USED
 YELLOW - NOT USED
 RED - LEFT SIGNAL
 BROWN - RIGHT SIGNAL
 BLUE - BRAKES
 GREEN - RUNNING LIGHTS

002-702945 WIRE BELL 2W/14GA MULTI-STRD

BLACK - RUNNING LIGHTS
 - BRAKES
 - BATTERY CHARGE
 WHITE - GROUND

5 FEET LONG BOTH SIDES

2 FEET LONG BOTH SIDES

8 FEET LONG BOTH SIDES

12 FEET LONG

22-1/2 FEET LONG

2 FEET LONG

6 FEET LONG

THE INFORMATION CONTAINED IN THIS DRAWING IS THE SOLE PROPERTY OF DRYAIR 2000 INC. AND ANY REPRODUCTION ON PART OR WHOLE WITHOUT THE WRITTEN PERMISSION OF DRYAIR 2000 INC. IS PROHIBITED

P.O. Box 126, Highway Drive
 St. Brieux Sask, Canada, S0K 3V0
 Tel: (306) 275-4648 Fax: (306) 275-4664
 Email: a.pap@dryair.ca

Rev#	Date	Description	Eng.
Material			
Finish			
Specification			
Unless otherwise specified dimensions are in inches			
Tolerances are: ±.125 ±.010 ±.1 deg.			
DRAWING TITLE: WIRING SCHEMATIC NEW GENERATION TRAILERS OF			
Date	Drawn	Scale	DWG. NO.
FEB 23/11	LSB	Letter	10.1
			REV.



WIRING SCHEMATIC TRAILERS