

# ELECTRIC SCISSOR LIFTS



## COMPACT 2747 E COMPACT 3347 E

### Exceptional productivity

- Load capacity up to 1000 lbs (C2747 E)
- Driveable at full height
- Both inside and outside use with the same load capacity
- Extended platform
- Width of 3 ft 11 in
- Long working cycles

### Reliable and easy to maintain



[www.haulotte-usa.com](http://www.haulotte-usa.com)

**Haulotte**   
GROUP

More than lifting



# COMPACT 2047 E / 2747 E / 3347 E

ELECTRIC SCISSOR LIFTS

## TECHNICAL DATA

	COMPACT 2747 E	COMPACT 3347 E
Working height	32 ft 9 in	38 ft 9 in
Platform height	26 ft 9 in	32 ft 9 in
Driveable at full height up to	26 ft 9 in	32 ft 9 in
Lift capacity - inside	1000 lbs	650 lbs
Lift capacity - outside	1000 lbs	650 lbs
<b>A</b> Platform length - outside	6 ft 7 in	7 ft 7 in
<b>B</b> Platform length - extended	10 ft 7 in	10 ft 7 in
Extension length	3 ft	3 ft
<b>C</b> Platform width - outside	3 ft 11 in	3 ft 11 in
<b>E</b> Storage height	4 ft 7 in	5 ft
<b>D</b> Height - stowed	7 ft 5 in	7 ft 10 in
<b>F</b> Overall width	3 ft 11 in	3 ft 11 in
<b>G</b> Length	8 ft 2 in	8 ft 2 in
<b>H</b> Wheelbase	6 ft 1 in	6 ft 1 in
<b>I</b> Ground clearance	6 in	6 in
Ground clearance - Pothole guards deployed	1 in	1 in
Drive speed	0.5 - 1.8 mph	0.5 - 1.8 mph
Gradeability	23 %	23 %
Lift / lower speed	32 s / 42 s	58 s / 52 s
Turning radius - outside	8 ft 2 in	8 ft 2 in
Non-marking tires	15x5	15x5
Batteries	24 V - 340 Ah (C20)	24 V - 340 Amph (C20)
Hydraulic system capacity	7 gal	7 gal
Weight	5,138 lbs	5,446 lbs

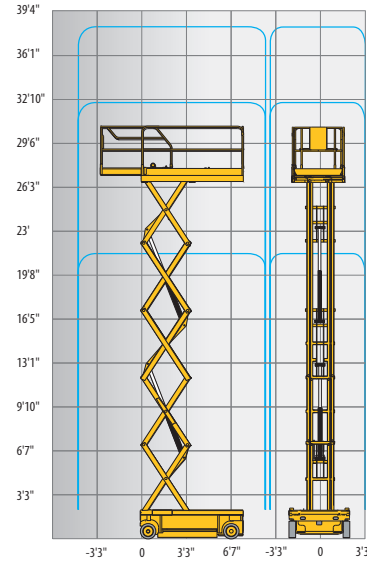

## STANDARD EQUIPMENT

- Pothole protection
- Battery charge indicator
- Proportional lift and drive
- Removable control box in platform
- Swing out component tray
- Battery charger 110V / 60Hz
- Non-marking tires
- Free wheeling device
- Tilt alarm
- Load management system in the platform
- Manual platform lowering valve
- Integrated forklift pockets
- Towing hooks
- Horn
- Hour meter

## OPTIONS AND ACCESSORIES

- Flashing light
- Travel alarm
- Working light
- Power to the platform
- Biodegradable hydraulic oil
- Folding guardrails
- Maintenance-free batteries
- Traction batteries
- Centralized battery filling

