

e240

ELECTRIC MINI EXCAVATOR



GREEN MACHINE
An **osc** Company



www.greenmachineco.com

e240 PRODUCT FEATURES & SPECIFICATIONS

MOTOR

- Zero Emissions
- 3-Phase AC Brushless
- Variable Frequency Drive
- Flat Torque Curve from 0 RPM
- Automatic Idle
- Working Modes: Power, Eco

BATTERY

- High Capacity Lithium Ion
- 56 kWh
- Sophisticated Battery Management System
- Stainless Steel Case
- Waterproof/Dustproof

ELECTRICAL

- 5.7" Color Multi-Informational Display (cab and canopy)
- Sealed Rocker Switches
- 12 volt System with 40 amp DC-DC Converter
- Ground Disconnect Switch
- LED Work Lights; Boom and Side Cover
- 120V/20A Convenience Outlet
- Travel Alarm
- Horn

UNDERCARRIAGE & FRAME

- Triple Flanged Track Rollers
- Two-Speed Travel with Automatic Shift
- High Torque Planetary Final Drive
- Heavy Duty Dozer Blade with Float
- Large Wrap Around Counterweight
- 13.8" Rubber Tracks
- 13.8" Steel Tracks (optional)
- Power Angle Blade with Float and Bolt-on Cutting Edge (optional)

OPERATOR'S STATION

- ROPS / TOPS / OPG (ISO 10262 Level 1) Four Post Canopy
- Deluxe High Back Suspension
- Seat Adjustable Arm Rests
- Proportional Slide Switch for Auxiliary Hydraulics
- 2" Retractable Seat Belt
- 3" Retractable Seat Belt (optional)
- Cab with Heat Defrost, Windshield Wiper and Washer, Skylight with Sun shade, AM / FM / MP3 Radio, 12v Power Outlet (optional)

HYDRAULIC & WORKING EQUIPMENT

- Variable Displacement, Open Center Hydraulics
- High Capacity Hydraulic Oil Cooler
- Large Hydraulic Reservoir with Fluid Level Sight Gauge
- Cushioned Boom, Arm, and Swing Cylinders
- Main Boom Cylinder Guard
- Hydraulic Pilot Controls
- Proportional Auxiliary Controls with Detent
- Primary Auxiliary Hydraulic Circuit Plumbed to Arm
- Flow Selector Valve, Primary Auxiliary Circuit
- Pattern Change Valve (ISO or SAE)
- Pilot Accumulator
- Long Arm with Integrated Thumb Mount
- Dual Pin Position Bucket (optional)
- Mechanical Bucket Quick Coupler (optional)
- Main Pin Hydraulic Thumb (optional)



Angle Blade with Reversible Bolt On Cutting Edge



Track Options - Rubber or Steel



2-Speed Travel w/ Auto Shift



Integrated Anchor Points



Triple Flanged Track Rollers



Multi-Function Switch Bank

Delivering outstanding performance and versatility, the e240 is one of Green Machine's most popular conventional tail swing excavators. The e240 offers steel construction and lockable service access panels, an automotive styled interior, and a smooth and powerful hydraulic system. The e240 has excellent breakout force, reach and lifting capacity for maximum productivity making it a great choice for the most demanding applications.

Additional features include automatic idle, heavy duty cooling module, and a large wraparound counterweight that protects battery components from damage. The interior offers excellent operator comfort with pilot operated controls, travel controls with large foot pedals, foot operated boom swing, easy to reach rocker switches and a dial throttle control.



Large lockable service hoods provide vandalism protection and outstanding maintenance access.

OPERATING PERFORMANCE

Operating Weight - Canopy	8,570 lb	(3,890 kg)
Cab	8,990 lb	(4,080 kg)
Maximum Bucket Breakout Force	9,959 lb	(4,517 kg)
Maximum Arm Digging Force	4,110 lb	(1,864 kg)
Arm Length	5 ft 3 in	(1,600 mm)
Slew Speed	9.6 rpm	
Traction Force	9,533 lb	(4,324 kg)
Ground Pressure - Canopy	4.4 psi	(30.2 kPa)
Cab	4.6 psi	(31.6 kPa)
Max Travel Speed		
Low Range	1.8 mph	(2.9 km / hr)
High Range	3.3 mph	(5.3 km / hr)

FLUID CAPACITIES

Hydraulic Reservoir Capacity	10.8 gal	(41.0 L)
Hydraulic System Capacity	19.5 gal	(74.0 L)

HYDRAULIC SYSTEM

Total Hydraulic Flow	30.6 gpm	(115.8 Lpm)
Auxiliary Hydraulic Flow	17.1 gpm	(64.9 Lpm)
System Operating Pressure	3,481 psi	(24.0 MPa)

MOTOR

Horsepower @ 4000 rpm	62 hp (46.2kW)
Torque @ 0 rpm	216 ft-lb (292.9 Nm)*
*at pump shaft after speed reducer	



Display





Long Arm with Thumb Mount



Convenient Serviceability

e240 Lifting Capacities at Ground Level*

Lift Point Radius from Rotation Axis	9 ft (2,743 mm)		12 ft (3,657 mm)	
 Lifting Capacities Over Front, Blade Down	3,683 lb	(1,670 kg)	2,462 lb	(1,116 kg)
 Lifting Capacities Over Side	2,019 lb	(915 kg)	1,356 lb	(615 kg)

* Ratings based on ISO10567 and do not exceed 87% of hydraulic lift or 75% of tipping load.

ATTACHMENTS

Green Machine now offers attachments for all of your Green Machine equipment. See your authorized Green Machine dealer for additional information and attachment options.

e240 COMPACT EXCAVATOR

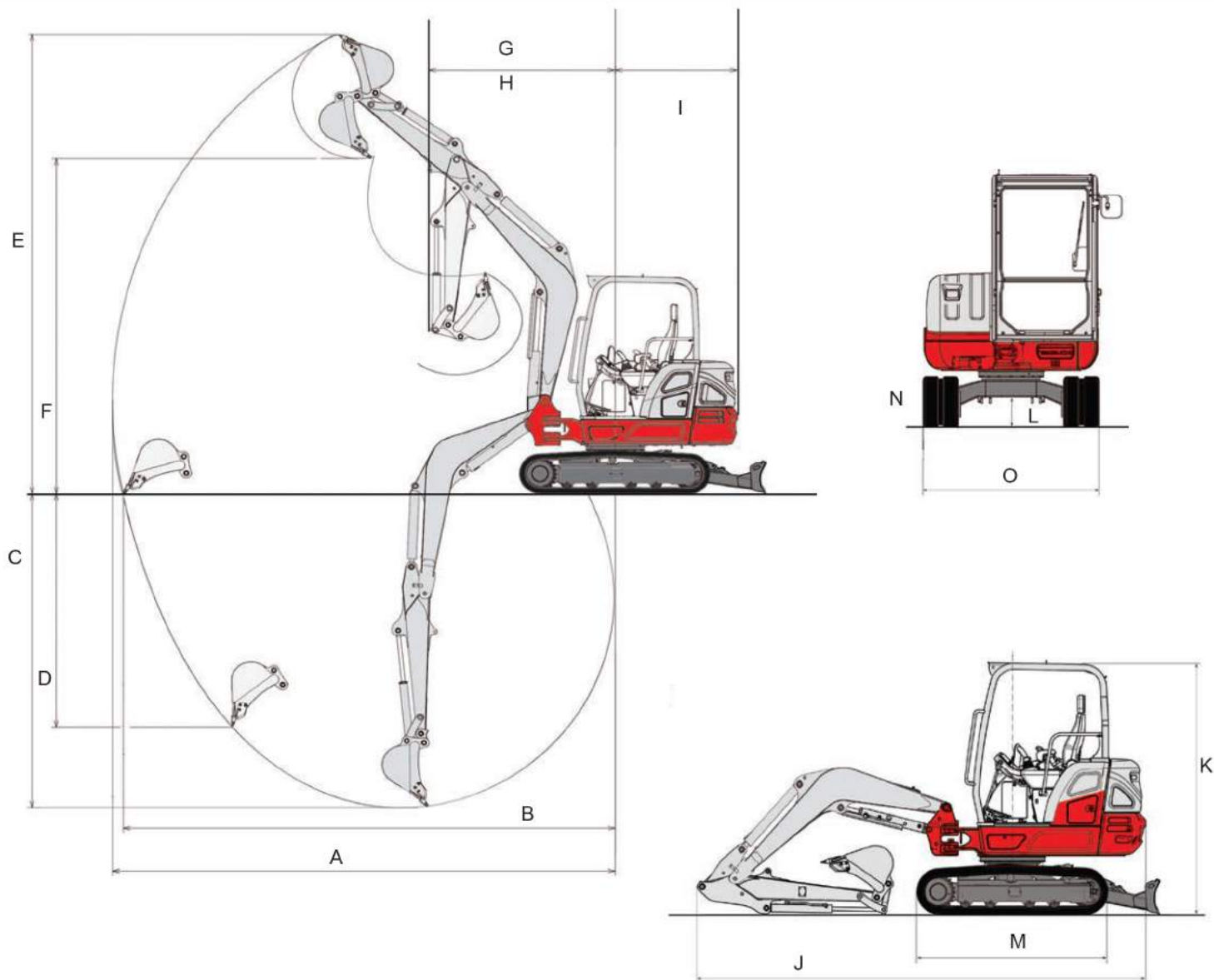

MACHINE DIMENSIONS

A	Maximum Reach	18 ft 2.3 in	(5,545 mm)
B	Maximum Reach at Ground Level	17 ft 9.6 in	(5,425 mm)
C	Maximum Digging Depth	11 ft 4.4 in	(3,465 mm)
D	Maximum Vertical Digging Depth	8 ft 8.9 in	(2,665 mm)
E	Maximum Dig Height	17 ft 2.5 in	(5,244 mm)
F	Maximum Dumping Height	12 ft 6.7 in	(3,828 mm)
G	Front Swing Radius	6 ft 8.2 in	(2,037 mm)
H	Front Swing Radius with Boom Offset	5 ft 4.0 in	(1,626 mm)
I	Tail Swing (Slew) Radius	4 ft 5.7 in	(1,365 mm)
J	Transport Length	16 ft 8.2 in	(5,020 mm)
K	Transport Height	8 ft 2.6 in	(2,505 mm)
L	Ground Clearance	11.6 in	(295 mm)
M	Undercarriage Length	6 ft 11.0 in	(2,110 mm)
N	Track Width (Rubber)	13.8 in	(350 mm)
O	Undercarriage Width	5 ft 8.5 in	(1,740 mm)

e240

ELECTRIC MINI EXCAVATOR



2 YEAR
2,000 HOUR
FULL MACHINE
WARRANTY

www.greenmachineco.com