

ECOVOLVE



Ecovolve Owners Manual | Ver 1.0

TABLE OF CONTENTS

SECTION 1

Service Schedule	iv
Foreword	1
1.0 Information About This Manual.....	2
1.1 Warranty & Liability.....	3
1.2 Trained Personnel Maintenance	3
1.3 Replacement Parts	4
1.4 Intended Use	4
1.5 Safety Information	5

SECTION 2

OPERATORS HAND BOOK	10
Electric Dumper Important Information.....	12
Driving the ED	13
Tiller Controls.....	14
Dash Controls	15
Parking the ED	16
Operator's Safety Rails & Platform	17
Electric Charging	18
Transportation	21
Cleaning the ED.....	23
Daily Checklist	24

SECTION 3

FIRST 150 HOUR MAINTENANCE SCHEDULE (Rear Drive Unit Only)	25
--	----

SECTION 4

50 WORKING HOUR INSPECTION SCHEDULE 29

Chassis and Truck Frame 32

Wheels..... 33

Steering & Dashboard 34

Lubrication..... 36

Hydraulic System 38

Rear Drive Unit 40

Braking System 41

Electric Charging 42

Safety Booklet 43

SECTION 5

500 WORKING HOUR MAINTENANCE SCHEDULE 44

Chassis & Truck Frame 46

Wheels..... 47

Steering & Dashboard 48

Lubrication..... 50

Hydraulic System 52

Rear Drive Unit 54

Braking System 57

SECTION 6

2000 WORKING HOUR MAINTENANCE SCHEDULE 59

Rear Drive Unit 61

SECTION 7

Service Schedule Forms..... 63

SECTION 8

Troubleshooting 70

SERVICE TIMETABLE - QUICK REFERENCE

SERVICE ITEM	ACTION	Every 50 working hours	Every 500 working hours	Every 2000 working hours
Chassis And Truck Frame	Check all safety symbols and décor is clearly visible	•		
	Check operator safety rails and platform	•		
	Check all fixings	•		
	Inspect for any damage of load bearing parts		•	
	Check all rams and joints		•	
Wheels	Check wheel nuts are tight	•		
	Check wheel bearings	•		
	Check wheels for wear and damage		•	
Steering & Dashboard	Check all steering functions & switches	•		
	-Traction paddles	•		
	-Speed switch	•		
	-Body protection switch	•		
	-Horn switch	•		
	-Safety buzzer	•		
	-Multi function display	•		
	-Skip lever functions	•		
	-Emergency stop button	•		
	-Lighting switches	•		
	-Remote control (if applicable)	•		

SERVICE TIMETABLE - QUICK REFERENCE

SERVICE ITEM	ACTION	Every 50 working hours	Every 500 working hours	Every 2000 working hours
Steering & Dashboard contd.	-Light display	•		
	-Check all sensors	•		
	-Test drive machine	•		
Lubrication	Check all 15 grease nipple fittings for proper lubrication, add grease as needed	•	•	
Hydraulic System	Check hydraulic system for leaks	•	•	
	Check hydraulic rams	•		
	Check oil level	•		
	Check hydraulic performance	•		
	Replace hydraulic oil		•	
Rear Drive Unit	Commence first oil change @ working 150hrs, then at 2000 working hours			
	Check oil level	•	•	
	Grease gears and check for wear		•	
	Check for unnatural noise		•	
	Change oil (+ at first 150 working hours)			•
Braking System	Check brake performance	•	•	
	Add copper grease to braking system		•	
Electric Charging	Check charging system and cables	•		
Safety Booklet	Check safety booklet is in a useable condition	•		

ECOVOLVE

FOREWORD

This material is proprietary to Ecovolve, and is not to be reproduced, used, or disclosed except in accordance with written authorisation from Ecovolve. This Owners Manual document is written for use by the service technician and is designed to help the technician become fully knowledgeable of the Ecovolve electric dumper (referred to as 'ED 'or 'electric dumper') and all its systems in order to keep it running and in production.

The ED electric high tip dumper range are versatile new machines from Ecovolve which will revolutionise the dumper market. It is fully battery operated which means it can be used both indoors and outdoors with no pollution. There are no emissions, no fumes and very little noise which means it can be used for night work in cities and residential areas.

With its integrated charging system, the ED electric high tip dumper will automatically select the power available, be it 110v or 220v. When fully charged, it will operate for a typical working day and is very economical to operate.

The dumper is manufactured with high quality components, which ensures a long trouble free life. The dry battery system requires no maintenance. There is no requirement for fuel or fuel storage. The unit is fitted with super elastic tyres which eliminates the possibility of puncture. Running costs for ED range of electric high tip dumpers are minimal. The steering system significantly reduces the risk of unwanted tyre marks on tiles; terrazzo flooring etc. This makes it an ideal machine for use in clean room, shopping malls, hospitals and food processing plants.

Each new user must read the Operator's Hand Book before using any Ecovolve product for the first time.

This manual differs from the Operator's Hand Book which provides comprehensive instructions of how to operate any electric dumper manufactured by Ecovolve. The Operator's Hand Book must be kept in the operators manual cabin of the machine at all times. A copy of this manual is included within this document – see Section 2.

All maintenance personnel should read and understand the instructions in this service manual before performing maintenance and/or operational checks on the machine. All safety notices, warnings and cautions must be understood and followed when accomplishing repairs on the electric dumper.

1.0 INFORMATION ABOUT THIS OWNERS MANUAL

This manual contains, among other things, information on the intended operation of the electric dumper, the instructions of how to operate, maintain, and inspect the electric dumper safely. The troubleshooting section of this manual has additional instructions for safely diagnosing malfunctions of the electric dumper to maintain service and performance levels.

Information about this service manual including the specifications, illustrations, weight information and technical data are not binding and correspond to the state of the art at the time of creation. Ecovolve reserves the right to make changes without prior notice in the area of design, configuration, appearance and technology on account of the ongoing further development of the products.

Always strictly observe the safety instructions in this service manual, the operator's manual and the legal and trade association regulations at the usage location.

Despite the utmost care, we cannot rule out deviations from drawings or dimensions, computing errors, printing errors or incompleteness in this operator's manual. Therefore, we make no guarantee for the correctness and completeness of our statements in this Owners Manual.

We guarantee the faultless functionality of our products within the context of normal operating conditions.

However, no manual can address every possible risk. The end-user ultimately must apply sound judgment whenever using this product. It is up to you, the ED operator, to take good care when working and use its potential to the fullest. During the manufacturing process (if affixed with CE mark): Ecovolve adhered to all CE safety requirements. We carried out all compliance tests required by law. This is proven by the CE stamp shown on the identification plates. The manual provides you with important information on activating, driving, operating and maintaining a Ecovolve ED product.

It is essential you regularly complete the maintenance checklists and make sure it is done on time. Use the correct tools, products etc. specified in order to maintain valid warranty service for your electric dumper.

Please keep and save a complete, detailed record of the maintenance process. All maintenance procedures must be recorded; otherwise you will lose your warranty. Users, especially electric dumper truck drivers and maintenance personnel, must strictly adhere to regional and international safety regulations such as "Guidelines on correct and safe use of materials handling equipment".

User shall be responsible for any loss caused by improper use. Ecovolve Ltd will not be responsible for such loss. If you want to use an Ecovolve electric dumper for purposes that are not mentioned in the user manual, please contact distributor accredited by Ecovolve Ltd. Any modification of your truck, in particular fitting of equipment or conversion of the truck, is prohibited without the permission of the manufacturer.

1.1 WARRANTY & LIABILITY

To maximize your warranty, after each periodic inspection, proof must be submitted to Ecovolve by way of electronic submission on our website. This is the only way to prove a effective service has been completed by a competent and qualified person as per instructions in this service manual.

Warranty submission forms can be downloaded from our website. If you have any questions regarding your warranty please contact your local distributor. A copy of each periodic inspection form can also be found at the end of this manual. Please keep and save a complete, detailed record of the maintenance process. All maintenance procedures must be recorded; otherwise you will lose the warranty.

Users, especially electric dumper truck drivers and maintenance personnel, must strictly adhere to regional and international safety regulations including “Guidelines on correct and safe use of materials handling equipment”. (Overseas edition). User shall be responsible for any loss caused by improper use. Ecovolve Ltd will not be responsible for such loss. If you want to use an Ecovolve electric dumper for purposes that are not mentioned in the user manual, please contact dealers accredited by Ecovolve Ltd. Any modification of your machine, in particular fitting of equipment or conversion of the truck, is prohibited without the permission of the manufacturer.

1.2 TRAINED PERSONNEL MAINTENANCE

Do not make repairs yourself. Servicing should only be carried out by competent personnel. Service technicians are trained professionals and must be competent to carry out the periodic maintenance required to keep the ED range operating at peak performance and also to maximize your warranty.

Inspections and periodic service is vital to safe operation of the electric dumper. Adhere to a strict inspection, lubrication and maintenance schedule. Only use original approved spare replacement parts when carrying out repair work.

Keep the maintenance and service area clean, free from obstacles and anything which may cause personnel injury. Never wear loose objects or jewellery when servicing the electric dumper. Never attempt to weld or attach fittings to the dumper. This should only be completed by suitable personnel from Ecovolve. Never attempt to alter the dumper in any way, especially to drill holes on any locations of the machine

Any modification should only be completed by suitable personnel after consultation and authorisation from the design team. To comply with warranty conditions, please ensure that work carried out is recorded in the registration documents. Record and submit all necessary proof of scheduled service to Ecovolve. Use dedicated work supplies according to checking and maintenance overviews.

1.3 REPLACEMENT PARTS

The ED range has been designed to be extremely low maintenance. Therefore ordering spare parts is much less frequent than of traditional dumpers. For questions about the ED and orders for spare parts, please contact your local Ecovolve distributor.

If the need to order spare parts arises, please provide the following information in addition to the part numbers:

- ED model number
- Serial number/Year of manufacturing
- Delivery date

1.4 INTENDED USE

All Ecovolve electric dumpers have been built according to applicable standards and regulations. Operation by inexperienced persons or in an unintended manner, can result in hazards that can lead to personal risk and subsequent harm to the operator and persons in the operating area of the electric dumper. Improper use can damage the dumper as well as property in the vicinity of operation. As the electric dumper is designed to work in confined spaces such as narrow corridors and basements. It sits on a unique shaped chassis which allows it to turn on its own axis. It is therefore far more maneuverable than a conventional dumper. The electric dumper can easily empty its load at a maximum height of 1.8 meters. All associated risks must be addressed by the operator.

The electric dumper product range from Ecovolve is intended to transport and empty materials within the specified load capacity in normal operating conditions. It is the operators responsibility to use sound judgment to asses whether a ground material is compatible with use of the ED. If in doubt contact your nearest distributor. Unintended use can endanger the lives of operating personnel or other persons and cause injuries or extensive damage to the electric dumper.

The rules for the normal and proper use of industrial trucks must be followed under all circumstances by the responsible persons, in particular by the operators and service personnel.

Failure to read and understand the entire manual before using or servicing the product constitutes misuse. Always follow the warnings contained within this guide and on the ED to avoid incidents and accidents from occurring.

1.5 SAFETY INFORMATION

Ecovolve strives to identify foreseeable hazards associated with the use of its products. However, no manual can address every possible risk. The possibility of other dangers when using the dumper truck cannot be entirely excluded. The end-user ultimately must apply sound judgment whenever using the electric dumper. Improper or careless use might result in serious personal injuries or death. Below is an overview of steps, warnings and advice that can be taken to prevent and minimize the risk of injury. This list is not exhaustive and awareness to each local environment and situation must be exercised by the operator.

Failure to read and understand the entire manual before using or servicing the product constitutes misuse. Always follow the warnings contained within this guide and on the ED to avoid incidents and accidents from occurring.

Safety Features

Ecovolve has introduced many safety features to make the ED range safe and user friendly. An overview of these are as follows:

- Three operating speeds: Creeper for when the skip is raised (under 1 km), Walking (under 4km), and Full (7km). The ED automatically selects Creeper mode when the skip is in operation. It will automatically select the Walking mode when the step is in the raised position. The operator can manually select the slower speed at any time if necessary.
- The ED has two pull-up safety rails for extra stability for the operator. These must be used when the ED is in operation.
- The ED is fitted with standard features such as a beacon light, motion buzzer and LED lamps allowing for high visibility at all times.
- The operator can hold on with both hands on the tiller head.
- The ED is fitted with both dynamic and static brakes. When the ED is in reverse, if the operator collides with an object and is suddenly pushed forward, their body will engage the large red body protection switch which activates the brakes immediately. The ED must only be maneuvered in reverse and not driven for any distance.
- The ED has an emergency stop button which can be easily accessed at any time during operation by pushing down on the button.
- If the ED is switched on and unattended for a period of longer than six minutes, as a safety precaution the machine will automatically switch all power off.

The operator must always be aware of their surroundings and maintain vigilance for their safety and the safety of others.

Operating Instructions

Any operator must read and understand the operating instructions before operating the electric dumper. A copy of the Operators Manual should be kept in the cabin of the ED at all times. A copy of this manual can be found in this document – Section 2. Before performing production work, the operator should find a remote site to become familiar with the controls and machine response. The dumper shall be in serviceable condition before attempting to use it as described in the operating instructions. If the dumper is determined not to be in serviceable condition, notify the site or machine supervisor to have it repaired before use.

Damage and Defects

- Damages and other defects to the ED must be reported to the Supervisor immediately. EDs which are not safe to operate may not be used until they have been properly repaired.
- Safety installations and switches may not be removed or rendered unusable.
- Specified settings may only be changed with the approval of the manufacturer.

Danger Area

- People must not stand in the danger area of an industrial truck. Danger areas are those areas in which persons are in danger as a result of the movements of machines, their operating equipment, their load carrying devices (e.g. their attachments) or the loaded goods. This also includes the area which can be reached by falling goods or lowering or falling operating equipment and devices.

Driving Conditions

- Use lights in dark and dim areas. Always ensure that there are no pedestrians in the trucks rear swing area before turning.
- Under all travel conditions, operate the truck at a speed that will permit it to be brought to a stop in a safe manner.
- It is essential to keep your truck under control at all times.

Load

- Do not exceed the capacity of the dumper. The capacity appears on dumper identification plate and on the safety labels on the skip.
- Do not overfill the skip to impair the operators vision.
- Always make certain that the load is secured and arranged evenly in the skip.
- Do not allow people to ride on the dumper. Do not raise the skip over people. Never lift or lower the load when the truck is in motion. Unstable loads are a hazard to you and to your fellow workers.

Driving Routes and Tip Over

Stability is guaranteed if the electric dumper is used correctly according to specified targets.

- Driving routes shall be free of objects.
- Gradients used by the electric dumper cannot not exceed a max of 10°.
- Drivable uphill/downhill gradient cannot exceed a max of 15°.

Common reasons for a lack of stability are:

- Cornering at excessive speeds.
- Moving with the load raised.
- Moving with a load that is protruding to the side.
- Turning and driving diagonally across gradients.
- Driving on gradients with the load on the downhill side.
- Ramp edges or steps.

Tip over can occur with a combination of speed and sharpness of turn. This condition of instability is even more likely with an unloaded skip.

- Lateral tip over can occur loaded or unloaded by turning on a ramp.
- Longitudinal tip over can occur with a combination of overloading and load elevated.

Modification

Do not modify the dumper! Modifications automatically void the limited warranty and might make the dumper unsafe to use. Check with the manufacturer or regional distributor for use of approved attachments.

Chassis Safety

- Inspect the product as described in the maintenance schedule. Do not use the dumper unless it is in normal condition.
- Do not use the product until it is fully restored to normal condition.
- Only use manufacturer-approved replacement parts.
- Do not remove or obscure any label. All labels must be readable and undamaged.
- Inform all persons in the area that you are going to use the dumper and instruct them to take the necessary precautions about the dumper during operation.
- Clear all debris from your driving path.

OPERATORS PERSONAL PROTECTIVE EQUIPMENT (PPE)

HARD HAT REQUIRED When the instruction for a hard hat is stated, a hard hat must always be worn when operating the machine to avoid personal injury.



PROTECTIVE EYEWEAR REQUIRED When the instruction for protective eyewear is stated, protective eyewear must always be worn when operating the machine to avoid personal injury.



SAFETY SHOES REQUIRED When the instruction for safety shoes is stated, safety shoes must always be worn when operating the machine to avoid personal injury.



APPROPRIATE CLOTHING REQUIRED When the instruction for safety clothing is stated, safety clothing must always be worn when operating the machine to avoid personal injury.



HAND PROTECTION REQUIRED When the instruction for hand protection is required to avoid personal injury.

SAFETY SYMBOL EXPLANATION



CAUTION! Indicates a hazardous situation which, if not avoided, could result in moderate injury.



ELECTRICAL WARNING! Indicates a hazardous situation which, if not avoided, could result in death or serious injury.



CRUSH PARTS WARNING! Indicates a hazardous situation which, if not avoided, could result in death or serious injury.



WHEEL CRUSH WARNING! Indicates a hazardous situation which, if not avoided, could result in serious injury.



NO NAKED FLAME! Indicates if naked flames are used in situations where naked flames are prohibited, a serious accident can occur.



NO SMOKING! Indicates if smoking occurs where a restriction is in place, a serious accident can occur.



ADVISORY TEXT WARNING! Indicates that the following text advice must be adhered to.



Reverse Hazard Warning

REVERSE HAZARD WARNING! Indicates a hazard is present to the operator and pedestrians while reversing. Extra attention is needed.

SAFETY SYMBOL EXPLANATION

	1	2	3	4	5	6		
	7	8	9	10	11	12	13	14
1	DANGER! Operator must read and understand the operator's manual, directions on signs and labels before use.							
2	DANGER! Operator must wear the correct Personal Protective Equipment (PPE) to ensure safe use.							
3	DANGER! Crush hazard. Can cause serious injury or death. Keep clear.							
4	DANGER! Do not drive on incline with the skip raised. High risk of tip over causing injury.							
5	DANGER! Do not enter the turning circle of the machine at all times.							
6	DANGER! Do not raise the skip while moving. Risk of tipping over causing injury or death.							
7	WARNING! Indicate change of direction on turning.							
8	DANGER! Crush hazard. Can cause serious injury or death. Avoid moving mechanisms.							
9	DANGER! Crush hazard. Can cause serious injury or death. Keep out of the danger zone while loading.							
10	DANGER! Do not exceed the max load rating.							
11	DANGER! Do not empty skip on decline. High risk of tipping over causing injury or death.							
12	DANGER! Risk of over turning over. Max permissible gradient is 15 degrees.							
13	DANGER! Driveable uphill max permissible gradient is 10 degrees.							
14	DANGER! Indicate change of direction on turning.							

Section 2

OPERATORS HAND BOOK



The operator must read and understand the Operator's Hand Book before attempting to operate the ED.

The Operator's Hand Book must be stored in the battery compartment on the ED at all times.

OPERATORS HAND BOOK CONTENTS

Electric Dumper Important Information	12
Driving the ED	13
Tiller Controls	14
Dash Controls	15
Parking the ED.....	16
Operator's Safety Rails & Platform.....	17
Electric Charging.....	18
Transportation	21
Cleaning the ED	23
Daily Checklist.....	24

All electric dumpers from Ecovolve are very user friendly machines to drive and operate. They are carefully manufactured with high quality components which ensure a long trouble free life. Whilst being designed, many safety features were considered and built in as standard to protect the operator and fellow work colleagues.

Before operation of the electric dumper, it is essential that the operator has:

- Read Section 1 of the Owners Manual.
- Understands what safety features are present in the electric dumper, these are before operation of the machine.
- Understands all operational functions and safety symbols present on the electric dumper.

ELECTRIC DUMPER IMPORTANT INFORMATION

- The ED has three operating speeds: Creeper for when the skip is raised (under 1 km), Walking (under 4km), and Full (7km). The ED automatically selects Creeper mode when the skip is in operation. It will automatically select the Walking mode when the step is in the raised position. The operator can manually select the slower speed at any time if necessary.
- The ED has two pull-up safety rails for extra stability for the operator. These must be used when the ED is in operation.
- The operator can control the ED with both hands on the tiller head.
- The ED is fitted as standard with a beacon light, motion buzzer and LED lamps allowing for high visibility at all time when in operation.
- The ED is fitted with both dynamic and static brakes. When the ED is in reverse, if the operator collides with an object and is suddenly pushed forward, their body will engage the large red body protection switch which activates the brakes immediately. The ED must only be maneuvered in reverse and not driven for any distance.
- When the battery charge is low, the ED will automatically override the speed switch setting and default to LIMP mode. The operator **MUST** navigate the ED to the nearest power point and recharge the battery fully before continuing with work duties.

DRIVING THE ED

- With the tiller control in the central position, pull out the e-stop button (Fig 1, Section 2).
- Before trying to start the ED, make sure the and the E-stop button is in the out position. (Fig 2, Section 2).
- When key is then turned clockwise the EDs traction wheel will reset and the machine is then ready to drive. (Fig 3, Section 2)
- For forward motion of the ED the traction paddles are pressed upwards and for reverse motion the traction paddles are pressed downwards (Fig 4, Section 2).
- The speed of the ED depends on the set position of the speed control switch (Fig 5, Section 2) and if the operator's platform is in use.

Fig 1: The ED tiller in drive position.

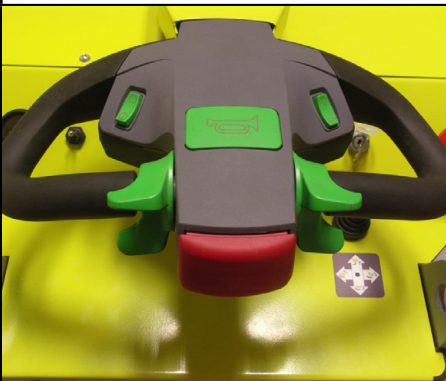

Fig 2: To start machine make sure the Emergency Stop button is raised up.



Fig 3: Turn the key clockwise to position II to start the ED.



Fig 4: Traction paddles. UP =Forward | DOWN = Reverse.

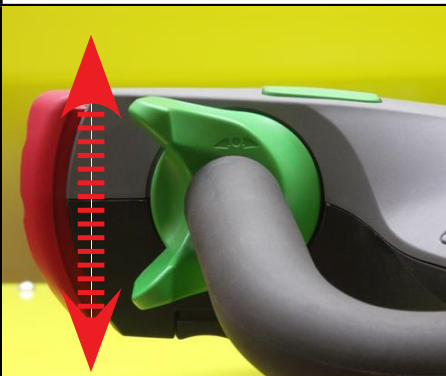
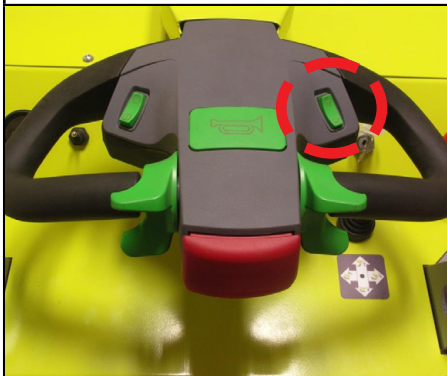

Fig 5: Speed Switch. Two options SLOW and FAST.



TILLER CONTROLS

- The operator must familiarise themselves with all functions and controls of the tiller before operation of the electric dumper. Please study Fig 6 to Fig 14, Section 2 below.

Fig 6: Beacon Light & Motion Buzzer ON/OFF Switch.

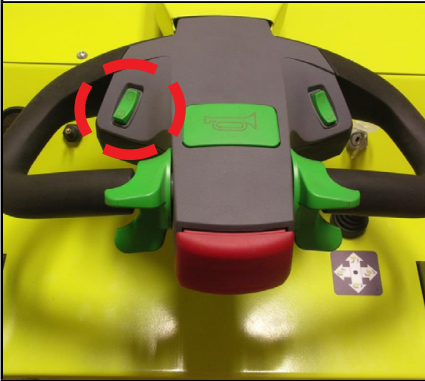

Fig 7: Horn Switch: Pressed IN will sound horn.

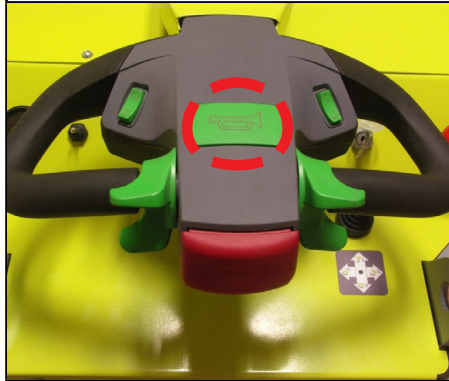

Fig 8: Traction paddles. UP = Forward | DOWN = Reverse.

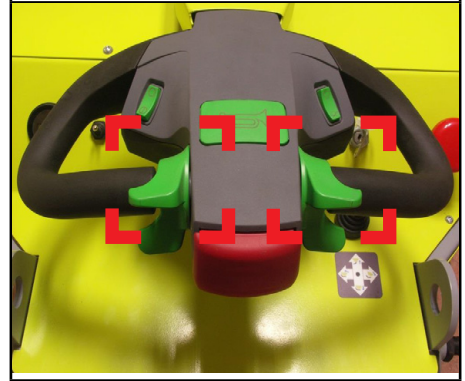
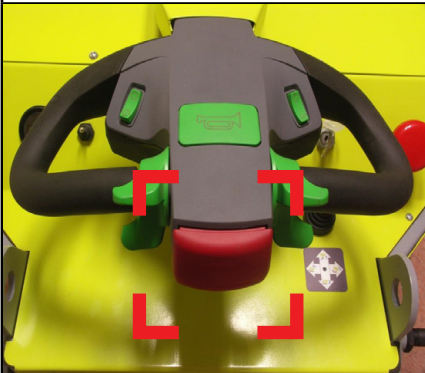

Fig 9: Body Protection Switch: Pressed IN will STOP the dumper while in reverse



DASH CONTROLS

- The operator must familiarise themselves with all functions and controls of the dash before operation of the electric dumper. Please study Fig 14 to Fig 18 below.



Fig: 10 Key Switch

To start the ED, make sure the Emergency Brake is raised up, turn the key clockwise to position II to start the ED.



Fig 11: Emergency Stop Button("E-stop")

Press the E-stop button to immediately interrupt all powered functions. Use the E-stop function if the control, driving or skip functions do not respond normally to operator commands.

Use the E-stop as a service brake to secure the ED when parked. To operate, the ED emergency stop button must be pulled up to the ON position before turning the start key.

If the emergency stop button is NOT in the ON position electrical power will not be transmitted to the ED and the machine will fail to start.



Fig 12: Multifunctional Display

Displays battery discharge (BDI), hour meter and error messages.

Error codes and troubleshooting can be found in the Troubleshooting section of the Owners Manual.

DASH CONTROLS CONTD.

- The operator must familiarise themselves with all functions and controls of the dash before operation of the electric dumper.

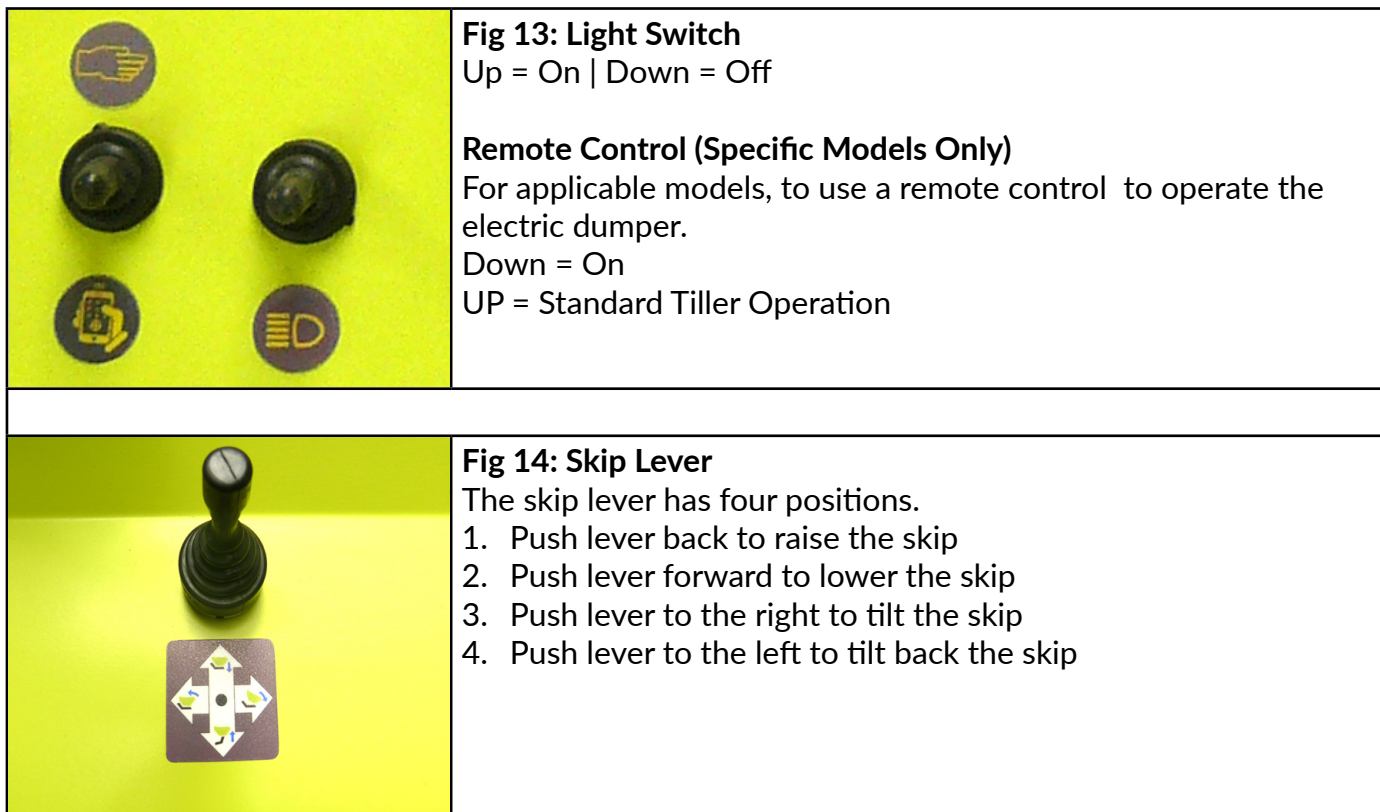

PARKING THE ED

- In the interest of safety, parking the electric dumper is the operator's responsibility.
- The operator must ensure to park the ED in a safe manner and not obstruct other traffic or people.
- When parking the ED the start key must be turned anticlockwise to power off the machine.
- For safety reasons the E-stop button must be pushed into the OFF position.
- If the ED is switched on and unattended for a period longer than six minutes, as a safety precaution the machine will automatically switch all power off.
- If storing the ED for any period longer than 7 days, fully charge the dumper before parking and ensure the e-stop button is pressed in. Failure to do so could result in damage to your battery.**

OPERATORS PLATFORM

- The ED has a two position platform for the operator to stand on when operating the machine.
- In the down position the operator can operate the ED standing on the platform, in the up position the operator can walk behind the ED.
- The ED will default to walk mode speed when the platform is placed in the up position.

OPERATORS SAFETY RAILS

- As an additional safety feature every ED is equipped with foldaway safety rails for the protection of the operator. When operator is operating the machine while standing on the operator's platform.
- It is the **operator's responsibility** to ensure that the safety rails are used and locked in the up position while the operator is using the operator's platform.
- To lock the safety rails in place, raise the safety rails up and turn the lock to secure them. Test before operation.

Fig 15: The ED platform in the **DOWN** position. When down, stand on the platform to operate the electric dumper



Fig 16: The ED platform in the **up** position. When **UP**, the operator can walk behind the electric dumper.









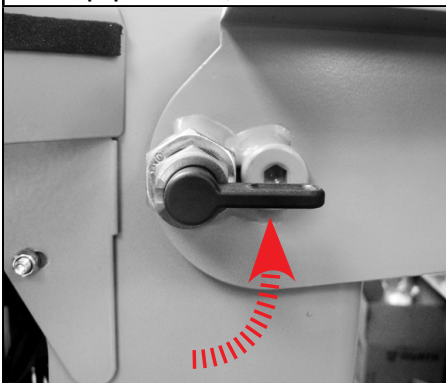
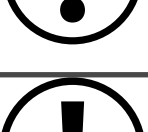

Fig 17: The ED with the safety rails up and locked into position.



Fig 18: The safety rail locked. Turn to lock the safety rails in the up position,



ELECTRIC CHARGING

	WARNING! Never operate the ED when charging!
	DANGER! The ED battery charger produces hazardous output voltages under normal operation. Exercise extreme care when working with the equipment and the battery.
	WARNING! Do not open or disassemble the charger. No user-serviceable parts are contained inside the unit. Do not operate charger if the AC supply cord is damaged or if the charger has received a sharp blow, or otherwise damaged in any way – refer all repair work to qualified personnel.
	DANGER! Connect charger power cord to an outlet that has been properly installed and grounded in accordance with all local codes and ordinances. A grounded outlet is required to reduce risk of electric shock – do not use ground adapters or modify plug. Do not touch the uninsulated portion of an output connector or uninsulated battery terminals. Disconnect the AC supply before making or breaking the connections to the battery.
	DANGER! When charging the battery it is absolutely prohibited to smoke or use a naked flame.
	All electric dumpers from Ecovolve are fitted with an internal automatic charging system. This charger has an automatic maintenance charging feature for a certain period after the mains charging period is complete. It will also eliminate the risk of overcharging the battery and the need to monitor the charging procedure.
	Ensure to switch off the ED before commencing charging.
	When connecting the charger to a 15A or 20A power outlet, the charger may draw up to a continuous 12A at 105V AC during normal operation. Supplying additional appliances from the same branch circuit may result in opening of the circuit breaker. Reduce the amount of load on the circuit, or have a larger capacity branch circuit installed.
	During charging, the surface of the charger may be become warm, especially in higher ambient temperatures. This is normal. Avoid touching the surface of the charger when in operation.
	The operational life of the battery is 7 hours between charges.

ELECTRIC CHARGING

- The charging compartment is located at the back of the ED. The charging compartment stores the Operator's Hand Book and the charging cables.
- Always remove the start key from the dashboard and use to open the charging compartment.
- The ED is supplied with two charging cables as standard. One 110V charging cable and one 220V charging cable.
 - 110V Charging cable has Blue plug and Yellow plug.
 - 220V Charging cable has Blue plug and Blue plug.
- When charging the ED the operator must determine what power source is being used on the work site 110V or 220V. If in doubt ask the supervisor.
- Both the 110V and the 220V charging cable has a blue plug, this is to be plugged into the blue socket in the charging compartment first and then the remaining plug is plugged in to the power source outlet socket.
- When the ED is fully charged, remove the power cable from the power outlet and return it to the charging compartment. Lock the charging compartment door and return the start key to the key slot on the dash. Turn back on the ED with the start key to recommence work after charging.

Fig 19: The ED charging compartment.



Fig 20: Match the correct voltage charger to the port.



ELECTRIC CHARGING

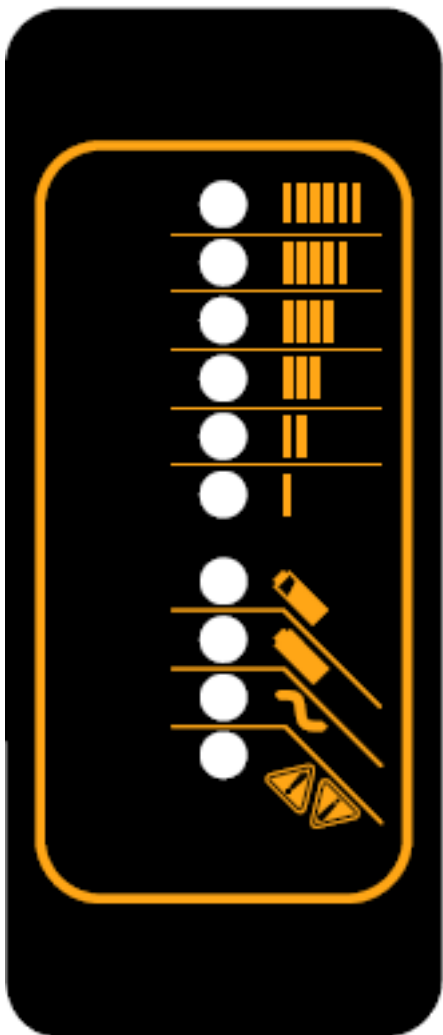

Ammeter (Amber)

Solid:

Displays approximate scale of current output during charging. Approximate current indicated by each Ammeter LED

A flashing “1” indicates the output is well below the “1” level. These are approximate levels.

Flashing:

Current output reduced to this level due to high internal charger temperature.

Solid (Start-up):

If an Algorithm from #1 through #6 is selected, it will be indicated by a solid light on the matching LED for 11 seconds when no battery is connected. In addition, the 80% LED below will flash.

80% Charge (Amber)

Solid: Bulk charge phase complete, 80% charged. Charger now in absorption phase.

Flashing: With no battery connected, indicates the charge algorithm # selected by the number of flashes.

100% Charge (Green)

Solid: Charging complete. If supported by the charge algorithm, the charger will enter Maintenance Mode.

Flashing: Absorption phase complete. Charger in Finish phase.

80% Charge (Amber)

Solid: Bulk charge phase complete, 80% charged. Charger now in absorption phase.

Flashing: With no battery connected, indicates the charge algorithm # selected by the number of flashes.

100% Charge (Green)

Solid: Charging complete. If supported by the charge algorithm, the charger will enter Maintenance Mode.

Flashing: Absorption phase complete. Charger in Finish phase.

AC On (Amber)

Solid: AC Power good

Flashing: Low AC Voltage, check voltage and extension cord length (max 100', 10 AWG).

Fault (Red)

Flashing: Charger or battery fault. Note the number of blinks between pauses reset charger power, and refer to Troubleshooting (Section 8).

TRANSPORTATION

The ED range are all easily transportable. It is comparatively lightweight for its capacity and can be loaded into any van with a load rating of 1500kg. The operator's platform and safety rails can be folded down for ease of transportation.



WARNING! When **LOADING** the ED on a suitable transporter or van ensure that the following points are adhered to.

- Use suitable ramps with an adequate loading capacity.
- Clean the ED to reduce the hazard of dirt and debris falling from the machine during transport.
- Confirm that the transport vehicle is serviceable for the transport task and that it is rated to carry a mass of 1500kg.
- Move the ED slowly and follow directions from people assisting with loading and alignment on the transport vehicle.
- Secure the ED to the transporter using only the ED anchor points and wheel chock's.



WARNING! When **LIFTING** the ED onto a suitable transporter ensure that the following points are adhered to.

- Confirm that the lifting device has adequate lifting capacity and reach to perform the lifting operation.
- Clean the ED to reduce the hazard of dirt and debris falling from the machine during transport.
- Use **ONLY** the lifting points to lift the ED onto a suitable transporter.



CRUSH PARTS WARNING! Indicates a hazardous situation which, if not avoided, could result in death or serious injury.

TRANSPORTATION OF MACHINE

- The ED has two lifting points and five anchor points which are used to lift and secure the machine when transporting.
- The two lifting points are designed so that the machine can be lifted safely on to a suitable transporter.
- The five tie down points are designed to anchor the machine to the transporter or to the floor of a van when the machine is in transit.
- Use certified slings and chains to secure the ED when being transported in a van or transporter.
- The assigned lifting and anchor points must be used in conjunction with approved belts or chains. At all times in transportation the ED must be anchored.
- When using the lifting eyes it is advised to use a 'D' shackle to connect them. This gives easier and safer connection for the chain hook when lifting.

TRANSPORTATION OF MACHINE CONTD.

- The ED has two lifting points and five anchor points which are used to lift and secure the machine when transporting.

Fig 21: The two lifting points on the electric dumper.

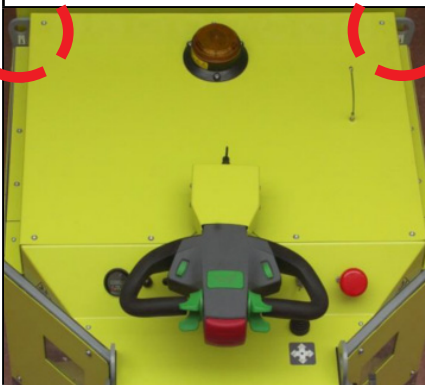

Fig 22: Lifting points on the ED are marked by this symbol

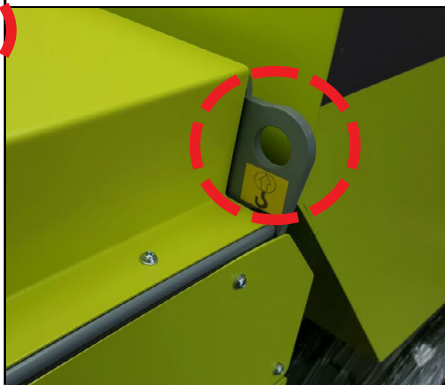

Fig 23: Anchor points located each side of the ED



Fig 24: Anchor points located each side of the ED

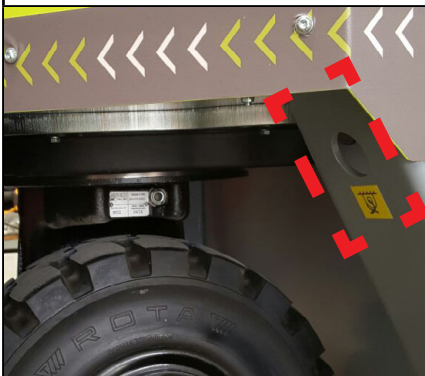

Fig 25: Anchor points located each side of the ED



Fig 26: Anchor points located each side of the ED



CLEANING & WASHING THE ED

- Do not power wash the machine.
- External cleaning can be performed by compressed air followed a wipe down with a suitable cleaning agent.
- Do not use pressurised water to clean the dumper as the water may enter the electrical cabinet causing a short circuit.
- The internals of the electrical cabinet should not get dirty so there will be no reason to clean it. Cleaning can be done during periodic maintenance.
- Remove debris build up from wheels daily.

DAILY CHECKLIST



WARNING! Failure to follow the daily checklist could result in a hazardous situation which could result in serious injury and damage to the ED.

Always carry out the daily checklist before operating the electric dumper.

If any item on the daily checklist fails, contact your site supervisor and **DO NOT OPERATE THE DUMPER BEFORE DOING SO.**

DAILY CHECKLIST	DATE	COMPLETED BY
Check the ED for damage and all décor is visible		
Check brakes		
Check tyres & wheels		
Check hydraulic hoses and connections for leaks		
Check the joystick function		
Check speed switch function		
Check sounder plinth, horn and beacon		
Check traction paddles		
Check body protection switch		
Check the DBI indicator for errors		
Check all lights		
Check E-Stop button		
Check operators platform & safety rails functions		
Check that all grease nipples are adequately greased		
Check the condition of the charging cables		
Notes:		

Section 3

FIRST 150 WORKING HOUR SERVICE (REAR DRIVE UNIT ONLY)



The following items must be serviced at the specified working hours. Proof must be submitted to Ecovolve that this service has been completed by a competent technician. To do this complete the relevant form and submit it to Ecovolve including all relevant vehicle identification information on www.ecovolve.eu

Failure to do this will reduce your warranty!

150 WORKING HOUR SERVICE (REAR DRIVE UNIT)

The following items must be serviced at the specified working hours. Proof must be submitted to Ecovolve that this service has been completed by a competent technician. To do this complete this form and submit it to Ecovolve including all relevant vehicle identification information at www.ecovolve.eu.

Failure to do this will reduce or void your warranty! The two ED Vehicle Identification Information items required can be found on the rear drive unit and chassis as shown below.

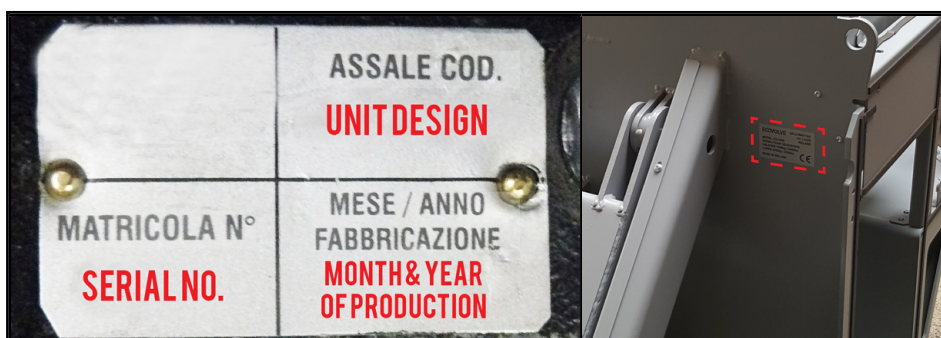

SERVICE ITEMS	DATE	COMPLETED BY
Rear drive unit oil change completed at or before the first 150 working hours.		
Required Oil: BP ENERGEAR HYPO 85W-140 Oil x 5 Litres.		

ED Vehicle Identification Information

ED Model:	
ED Serial Number & Year:	
Rear Drive Unit Serial Number:	
Rear Drive Unit Number:	
Rear Drive Unit Month And Year of Production:	
Working Hours Completed at Time of Service:	

Notes:

REAR DRIVE UNIT - FIRST OIL CHANGE



After the first 150 working hours of use, the rear drive unit requires its first oil change.

Following this service, check the oil level every 50 and 500 working hours and change the oil as per regular service intervals which is 2000 working hours.



CAUTION! Indicates a hazardous situation which, if not avoided, could result in moderate or serious injury.

- **Risk of burning from hot oil.** Allow the oil to cool before running maintenance checks.
- Relieve the system pressure slowly before starting service on the drive unit. Never use your hand to check for an oil leak. Use appropriate hand protection.
- Only fill the drive unit system with new clean recommended oil, if the oil is contaminated components may become damaged as a result.
- Always use the same original type of oil when topping up or changing.
- **The ED drive unit uses BP ENERGEAR HYPO 85W-140 Oil x 5 Litres**

INSTRUCTIONS

REAR UNIT OIL CHANGE @ FIRST 150 WORKING HOURS

- Before starting any service record the transmission identification number of the rear drive unit for submission to Ecovolve. This is required to maximise your warranty.
- Record the necessary information as shown and submit to Ecovolve at www.ecovolve.eu. A copy of this form is included at the end of this manual.
- The transmission identification number is printed on the well-visible tag placed on one side of the rear drive unit, as shown below.

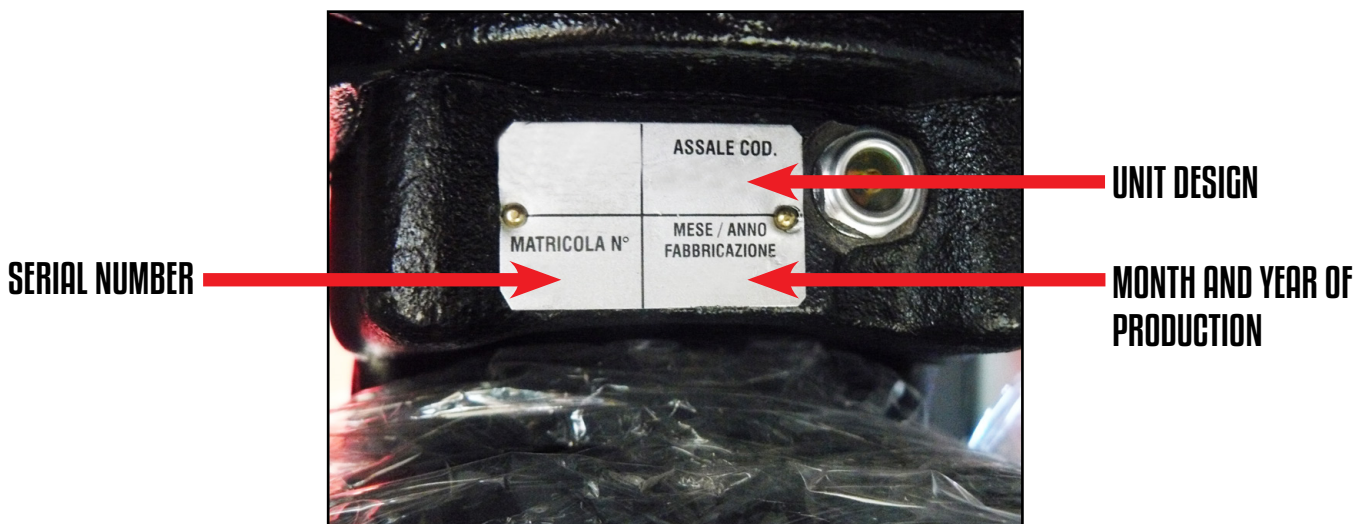

- Lay the vehicle on a flat surface and block the wheels.
- Clean the surface around the oil filling plug and the drain plug.
- Put an appropriate container under the drain hole.



N.B: When this operation is executed immediately after a long operating time, oil in the unit may be hot; please wear special gloves.

- Unscrew the drain plug (ref. 2) by means of an hex wrench 7 mm.
- Convey all the oil into the appropriate container. (Necessary draining time is about 5 min.)
- Clean the plug of the drain hole, apply sealant (ref. 2), screw it and fasten it with a tightening torque of 22 Nm.
- To make topping up easier, use a funnel and small hose. Hose diameter must be 12 mm max.
- During the topping up phase, turn the wheel shaft to prevent air bubbles from coming in.
- Screw the filling plug after having applied sealant (ref. 1) and fasten with a tightening torque of 22 Nm.
- Remove any oil drippings using a dry cloth.
- The oil level must be checked again after a short operating period. If necessary top up with the same oil to reach the correct level.
- **Record Result.**

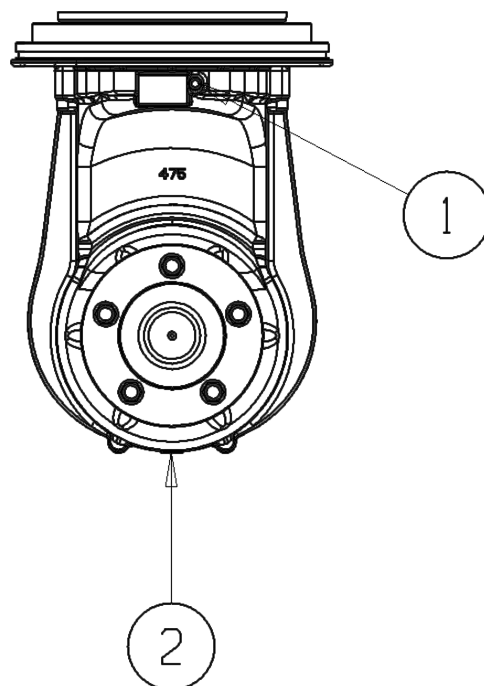

Section 4

50 WORKING HOUR INSPECTION



The following items must be serviced at the specified working hours.

The work must be completed by a competent technician.

Failure to do this will reduce your warranty!

50 WORKING HOUR INSPECTION

The following items must be serviced at the specified working hours. The work must be completed by a competent technician.

Failure to do this will reduce or void your warranty! The two ED Vehicle Identification Information items required can be found on the rear drive unit and chassis as shown below.



SERVICE ITEMS		DATE	COMPLETED BY
Chassis And Truck Frame	Check all safety symbols and décor is clearly visible		
	Check operator safety rails and platform		
	Check all fixings		
Wheels	Check wheel nuts are tight		
	Check wheel bearings		
Steering & Dashboard	Check all steering functions & switches:		
	-Traction Paddles		
	-Speed Switch		
	-Body protection switch		
	-Horn switch		
	-Safety buzzer		
	-Multi function display		
	-Skip lever functions		
	-Emergency stop button		
	-Lighting switches		
-Remote control (if applicable)			

50 WORKING HOUR INSPECTION

SERVICE ITEMS		DATE	COMPLETED BY
Steering & Dashboard Contd.	-Light display		
	-Check all sensors		
	-Test drive machine		
Lubrication	Check all 15 grease nipple fittings for proper lubrication, add grease as needed		
Hydraulic System	Check hydraulic system for leaks		
	Check hydraulic rams		
	Check oil level		
	Check hydraulic performance		
Rear Drive Unit	Check oil level		
Braking System	Check brake performance		
Electric Charging	Check charging system and cables		
<u>Safety Booklet</u>	Check safety booklet is in a useable condition.		

ED Vehicle Identification Information

ED Model:	
ED Serial Number & Year:	
Rear Drive Unit Serial Number:	
Rear Drive Unit Design:	
Rear Drive unit Month And Year of Production:	
Working Hours Completed at Time of Service:	

Notes:

CHASSIS AND TRUCK FRAME

1. Check all safety symbols and décor is clearly visible.
2. Check operator safety rails and platform.
3. Check all fixings.



CRUSH POINT WARNING! Indicates a hazardous situation which, if not avoided, could result in death or serious injury. Obey all safety messages that follow this symbol to avoid injury or death.

INSTRUCTIONS

1. CHECK ALL SAFETY SYMBOLS AND DÉCOR IS CLEARLY VISIBLE

- Check all safety symbols and décor is clearly visible around the skip, cabin and dashboard.
- If any damage has occurred, replace item immediately.
- For explanation of all symbols, please read Section 1: Safety Symbol Explanation.
- **Record Result**

2. CHECK OPERATOR SAFETY RAILS AND PLATFORM

- Check the condition and functions of the operator platform and safety rails in both raised and down position.
- If any damage has occurred, replace item immediately.
- For explanation of all symbols, please read Section 1: Safety Symbol Explanation.
- **Record Result**

Fig 1: The ED platform in the **DOWN** position. When down, stand on the platform to operate the electric dumper



Fig 2: The ED with the safety rails up and locked into position.



Fig 3: The safety rail locked. Turn to lock the safety rails in the up position,

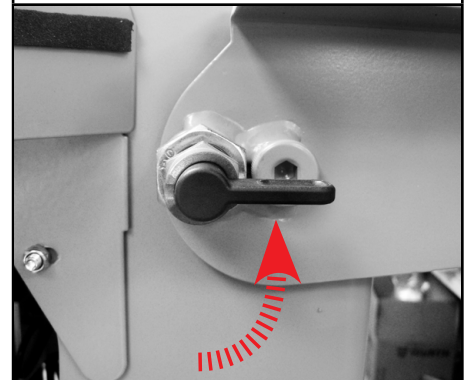

3. CHECK ALL FIXINGS

- Check all components, connections and fixings to the chassis are free from wear or damage.
- **Record Result**

WHEELS

1. Check wheel nuts are tight. Inspect wheels for wear and damage.
2. Check wheel bearings



WHEEL CRUSH WARNING! Indicates a hazardous situation which, if not avoided, could result in serious injury. Obey all safety messages that follow this symbol to avoid injury.

INSTRUCTIONS

1. CHECK WHEEL NUTS ARE TIGHT + INSPECT WHEELS FOR WEAR AND DAMAGE.

- Inspect all tyres for damage and trapped debris, remove debris where found.
- Inspect all wheels for 5 retaining nuts and check that the retaining nuts are tight.
- Tightening torque of the 5 M14x1,5 nuts is 140 – 150 Nm

Record Results

Fig 4: Remove debris if present



Fig 5: Tighten wheel nuts if loose to correct torque settings



2. CHECK WHEEL BEARINGS

- Inspect all wheel bearings for wear or signs of damage

Record Results

STEERING & DASHBOARD	Check all steering functions & switches.
	CAUTION! Ensure when testing the steering system that the test area is free from obstructions and pedestrians.

INSTRUCTIONS

CHECK ALL STEERING FUNCTIONS & SWITCHES

- The ED has three operating speeds: Creeper for when the skip is raised (under 1 km), Walking (under 4km) and Full (7km).
- It will automatically select WALKING mode when the operator's step is in the raised position.
- The operator can manually select the slower speed at any time if necessary.
- Ensure each mode works correctly.
- Complete each of the following tests to ensure each function of the steering system works correctly.
- **Record Results**

Fig 6: Ensure tiller locks in both drive and transport position (Tiller shown in transport mode below).



Fig 7: Tiller in drive position.

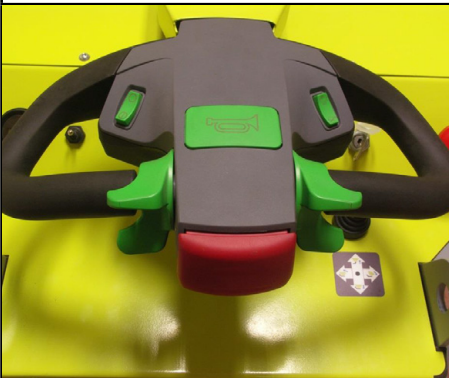

Fig 8: Traction paddles. UP forward /DOWN reverse

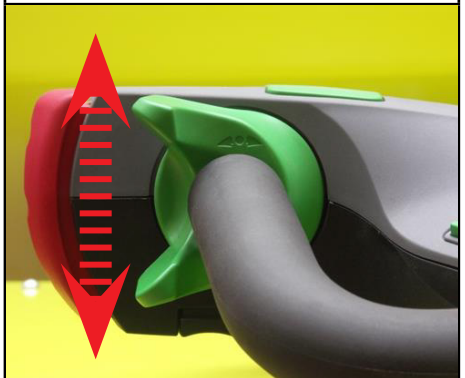

Fig 9: Speed Switch. Two options Creeper and Full.

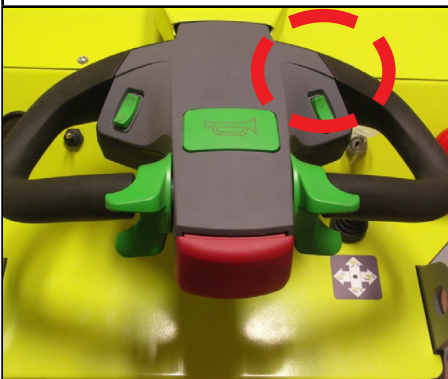

Fig 10: Body protection Switch. Pressed IN will STOP the ED when moving in reverse.

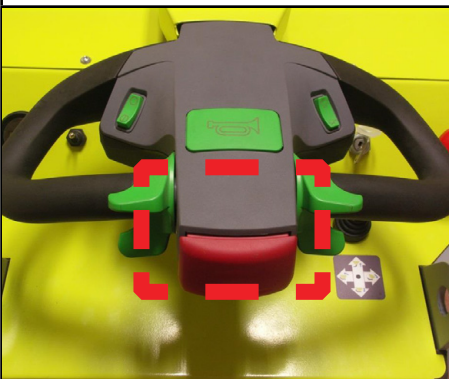

Fig 11: Horn switch. Pressed IN will sound horn.

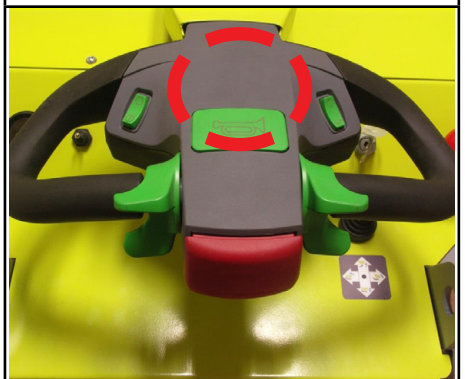

Fig 12: Press the flashing beacon & alert buzzer switch on the tiller control.

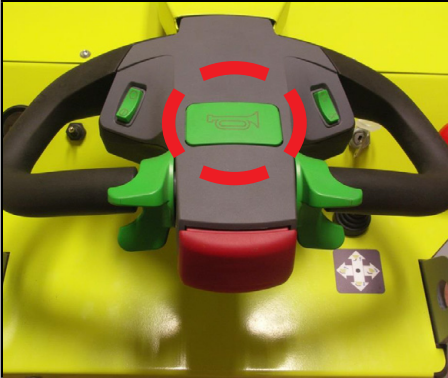

Fig 13: Ensure the flash beacon is working correctly.



Fig 14: Multi Function Display. Displays battery discharge (BDI), hour meter and error message display.



Fig 15: Skip lever. Ensure all 4 functions work correctly.



Fig 16: Emergency Stop. When pressed in stops machine.



Fig 17: Light switch. Up=ON / Down = OFF)



Fig 18: Remote Control. Up=ON /Down = OFF



Fig 19: Ensure rear facing lights are functioning and free from debris.



Fig 20: Ensure front facing lights are functioning and free from debris.



LUBRICATION

Check all 15 grease nipple fittings for proper lubrication, add grease as needed.



CRUSH POINT WARNING! Indicates a hazardous situation which, if not avoided, could result in death or serious injury. Obey all safety messages that follow this symbol to avoid injury or death.

- Ensure the ED is powered off and emergency switch is UP before expecting machine.
- Keep a safe distance back from the machine if another technician is operator the skip function

INSTRUCTIONS

CHECK ALL 15 GREASE NIPPLE FITTINGS FOR PROPER LUBRICATION, ADD GREASE AS NEEDED.

- Remove dust cap from nipple where caps are applied.
- Grease all grease nipple points with suitable grease using a grease gun. The ED range requires just one pump of a standard grease gun.
- Clean surplus grease from nipple with a clean damp cloth and reapply dust cap to nipple.
- **Record Results**

Fig 21: DUST CAP ON

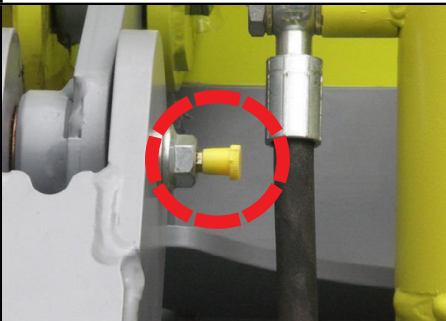

Fig 22: DUST CAP OFF

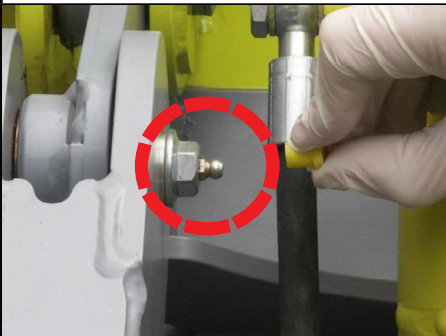

Fig 23: GREASE POINT 1

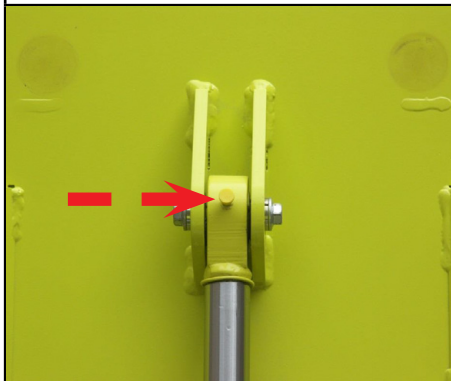

Fig 24: GREASE POINT 2

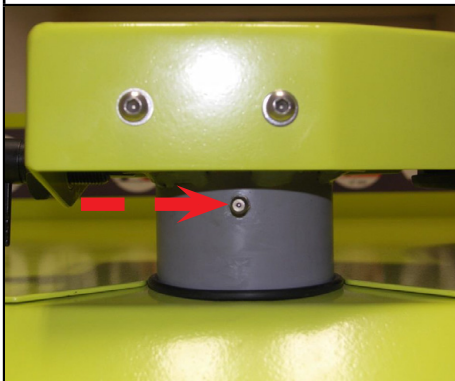

Fig 25: GREASE POINT 3-5

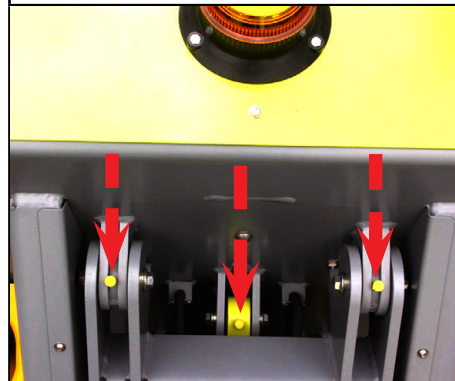

Fig 26: GREASE POINT 6-7

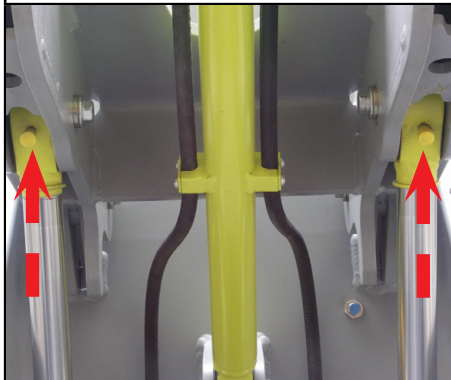

Fig 27: GREASE POINT 8-11

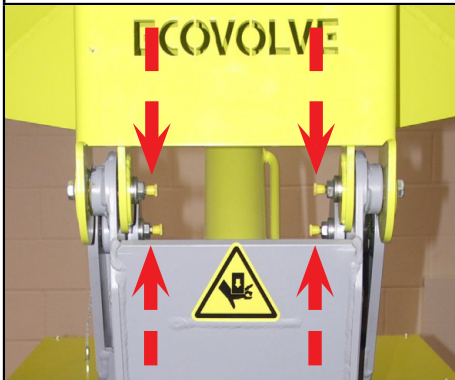

Fig 28: GREASE POINT 12-13

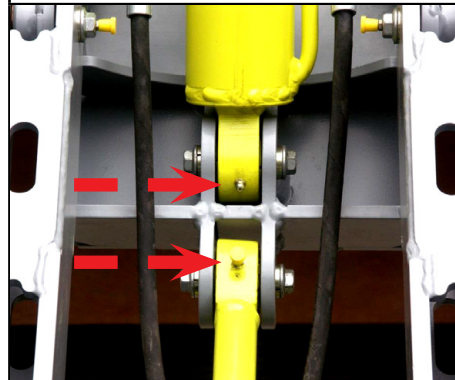
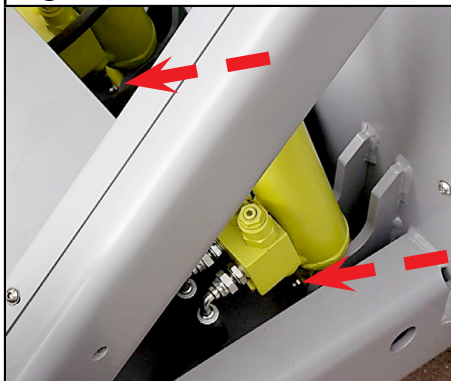





Fig 29: GREASE POINT 14-15



HYDRAULIC SYSTEM	<ol style="list-style-type: none"> 1. Check hydraulic system for leaks. 2. Check hydraulic rams. 3. Check oil level. 4. Check hydraulic performance.
	<p>CAUTION! Indicates a hazardous situation which, if not avoided, could result in moderate or serious injury.</p> <ul style="list-style-type: none"> • Risk of burning from hot hydraulic oil. Allow the oil to cool before running maintenance checks. • Never use your hand to check for an oil leak, hydraulic oil can be hot. Use appropriate hand protection. • Only fill the hydraulic system with new clean recommended hydraulic oil, if the oil is contaminated hydraulic components may become damaged as a result. • Always use the same original type of oil when topping up or changing. • The ED range uses HYD 46 Hydraulic oil. Tank capacity is 2.8 litres
	<p>CRUSH PARTS WARNING! Indicates a hazardous situation which, if not avoided, could result in death or serious injury. Obey all safety messages that follow this symbol to avoid injury or death.</p>
	<p>HAND PROTECTION REQUIRED! When the instruction for hand protection is required to avoid personal injury.</p>
	<p>PROTECTIVE EYEWEAR REQUIRED! When the instruction for protective eyewear is stated, protective eyewear must always be worn when operating the machine to avoid personal injury.</p>

INSTRUCTIONS

1 & 2. CHECK HYDRAULIC SYSTEM AND RAMS FOR LEAKS

When checking the hydraulic system and rams for leaks, protective gloves and glasses must be worn.

- Raise skip and remove start key from dash.
- Inspect system and rams for leaks or damage.
- Lower skip and inspect system for leaks and damage.
- **Record Results**

3. CHECK OIL LEVEL

- When checking the hydraulic oil level protective gloves and glasses must be worn.
- Raise skip and remove start key from dash. Screw tank cap anti clockwise and withdraw the level indicator.
- If hydraulic oil is needed fill with HYD 46 hydraulic oil to the full level on the dipstick.
- **Record Results**

Fig 30: Raise skip to access the oil dip stick. Take all precautions to avoid injury!

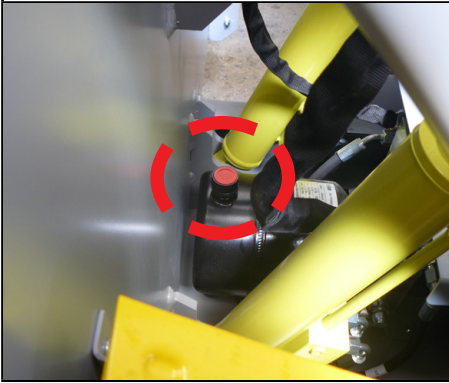

Fig 31: Unscrew the filler cap to reveal the oil dipstick.

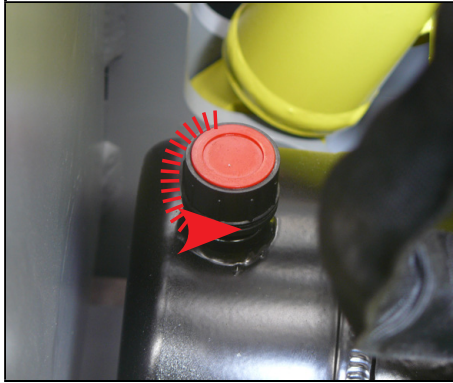
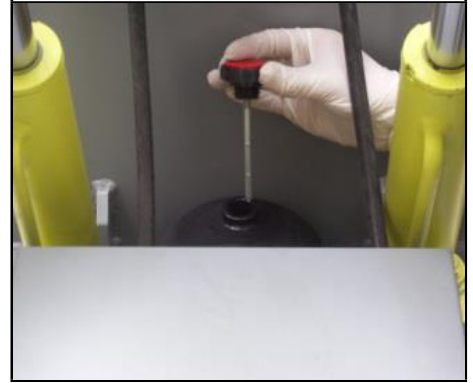



Fig 32: Check the level and top up oil if necessary.



4. CHECK HYDRAULIC PERFORMANCE

- Make sure area is free from obstructions or danger.
- Test all functions of the hydraulic system.
- **Record Results**

REAR DRIVE UNIT	Check oil level of rear drive unit.
	<p>After the first 150 working hours of use, the rear drive unit requires its first oil change.</p> <p>Following this service, check the oil level every 500 working hours and change the oil as per regular service intervals which is 2000 working hours.</p>
	<p>CAUTION! Indicates a hazardous situation which, if not avoided, could result in moderate or serious injury.</p>

INSTRUCTIONS

CHECK OIL LEVEL OF REAR DRIVE UNIT

- Securely park the ED and take all safety precautions.
- On the bottom of the rear drive unit, check oil level through viewing window.
- If low top up as necessary with **BP ENERGEAR HYPO 85W-140 Oil x 5 Litres.**
- **Record Results**

BRAKING SYSTEM	Inspect brake performance and adjust as needed.
	CAUTION! Indicates a hazardous situation which, if not avoided, could result in moderate or serious injury.

INSTRUCTIONS

1. INSPECT BRAKE PERFORMANCE AND ADJUST AS NEEDED

- Ensure area is free from objects and dangers.
- Test brake performance. If adjustment is needed continue as instructed below.
- To adjust brakes, jack up the ED and secure it on adequate capacity jack stands.
- Remove the adjusting hole cover from the adjusting slot on the bottom of the break backing plate.
- With a flat head screw driver rotate the star wheel of the adjuster to expand the brake shoe assembly.
- Adjust the brake shoes until the pressure of the lining against the drum makes the wheel difficult to turn.
- Then rotate the star wheel adjuster in the opposite direction until the wheel turns freely with a slight lining drag, replace the adjusting hole cover and lower the wheel to the ground.
- Repeat the same procedure for the opposite wheel.
- **Record Results**

Fig 33:



Fig 34: Adjust brake shoe as needed.



Fig 35: Star wheel

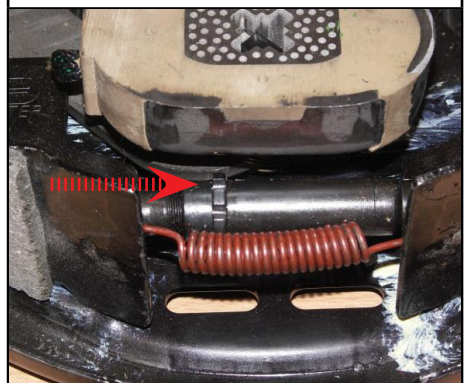

ELECTRIC CHARGING	Check charging system and cables.
	CAUTION! Indicates a hazardous situation which, if not avoided, could result in moderate or serious injury.

INSTRUCTION

1. CHECK CHARGING SYSTEM AND CABLES

- Plug in and test charging system and inspect cables for damage.
- **Record Results**

Fig 36: The ED charging compartment.



Fig 37: Match the correct voltage charger to the port.



SAFETY BOOKLET	Check safety booklet is in a useable condition.
	CAUTION! Indicates a hazardous situation which, if not avoided, could result in moderate or serious injury.

INSTRUCTION

1. CHECK SAFETY BOOKLET IS IN A USEABLE CONDITION.

- Check that all safety information is contained within the cabin of the ED.
- Ensure all manuals are in useable condition.
- **Record Results**

Section 5

500 WORKING HOUR SERVICE



The following items must be serviced at the specified working hours. Proof must be submitted to Ecovolve that this service has been completed by a competent technician. To do this complete the relevant form and submit it to Ecovolve including all relevant vehicle identification information on www.ecovolve.eu

Failure to do this will reduce your warranty!

500 WORKING HOUR SERVICE

The following items must be serviced at the specified working hours. Proof must be submitted to Ecovolve that this service has been completed by a competent technician. To do this complete this form and submit it to Ecovolve including all relevant vehicle identification information at www.ecovolve.eu. **Failure to do this will reduce or void your warranty! The two ED Vehicle Identification Information items required can be found on the rear drive unit and chassis as shown below.**



SERVICE ITEMS		DATE	COMPLETED BY
Chassis and Truck Frame	Inspect for any damage of load bearing parts		
	Inspect all rams and joints		
Wheels	Inspect wheels for wear and damage		
	Check wheel tightness		
Steering & Dashboard	Check for any wear or damage to the edges of the skip		
Lubrication	Check all 15 grease nipple fittings for proper lubrication, add grease as needed		
Hydraulic System	Check systems for leaks		
	Change hydraulic system oil		
Rear Drive Unit	Inspect for leaks and unusual noise		
	Grease gears and check for wear		
	Check oil level		
Braking System	Inspect brake performance and adjust as needed		
	Check for brake wheel wear		
	Spray copper grease in braking system		
ED Vehicle Identification Information			
ED Model:			
ED Serial No & Year:			
Rear Drive Unit Serial Number:			
Rear Drive Unit Design:			
Rear Drive Unit Month And Year of Production:			
Working Hours Completed at Time of Service:			

CHASSIS AND TRUCK FRAME

1. Inspect for any damage of load bearing parts.
2. Inspect all rams and joints.



CRUSH POINT WARNING! Indicates a hazardous situation which, if not avoided, could result in death or serious injury. Obey all safety messages that follow this symbol to avoid injury or death.

- Ensure the ED is powered off and emergency switch is UP before expecting machine.
- Keep a safe distance back from the machine if another technician is operating the skip function.

INSTRUCTIONS

INSPECT FOR ANY DAMAGE OF LOAD BEARING PARTS + ALL RAMS AND JOINTS

- Inspect all of the chassis, any load bearing parts plus all rams and joints.
- Do not operate machine if any damage is present and replace parts.
- **Record Result**

WHEELS

1. Check wheel nuts are tight.
2. Inspect wheels for wear and damage.



WHEEL CRUSH WARNING! Indicates a hazardous situation which, if not avoided, could result in serious injury. Obey all safety messages that follow this symbol to avoid injury.

INSTRUCTIONS

CHECK WHEEL NUTS ARE TIGHT + INSPECT FOR WEAR AND DAMAGE

- Inspect all tyres for damage and trapped debris, remove debris where found.
- Inspect all wheels for 5 retaining nuts and check that the retaining nuts are tight.
- Tightening torque of the 5 M14x1,5 nuts is 140 – 150 Nm.
- **Record Results**

Fig 1: Remove debris if present



Fig 2: Tighten wheel nuts if loose to correct torque settings



STEERING & DASHBOARD

Check all steering functions & switches.



CAUTION! Ensure when testing the steering system that the test area is free from obstructions and pedestrians. Observe all safety precautions.

INSTRUCTIONS

CHECK ALL STEERING FUNCTIONS & SWITCHES

- The ED has three operating speeds: Creeper for when the skip is raised (under 1 km), Walking (under 4km) and Full (7km).
- It will automatically select CREEPER mode when the skip is in operation.
- It will automatically select WALKING mode when the operator's step is in the raised position.
- The operator can manually select the slower speed at any time if necessary.
- Ensure each mode works correctly.
- Complete each of the following tests to ensure each function of the steering system works correctly.
- **Record Results**

Fig 3: Ensure tiller locks in both drive and transport position (Tiller shown in transport mode below).



Fig 4: Tiller in drive position.

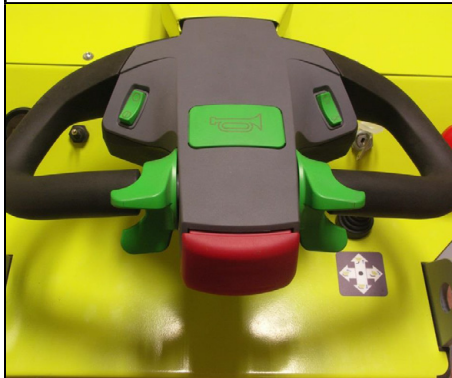

Fig 5: Traction paddles. UP forward /DOWN reverse

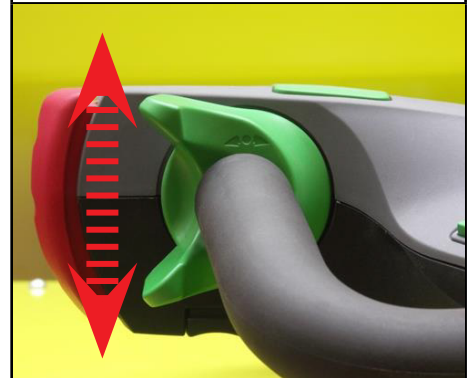

Fig 6: Speed Switch. Two options Creeper and Full.

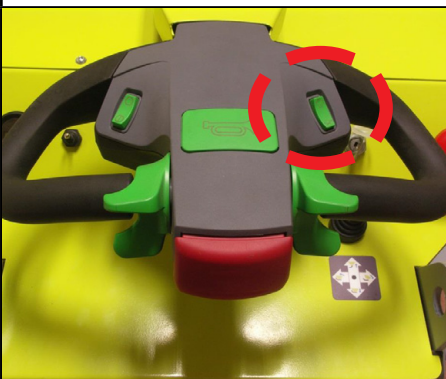

Fig 7: Body protection Switch. Pressed IN will STOP the ED when moving in reverse.

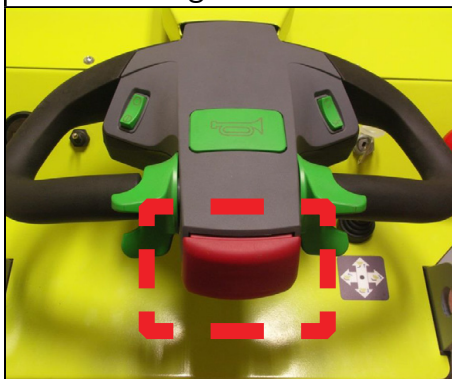

Fig 8: Horn switch. Pressed IN will sound horn.

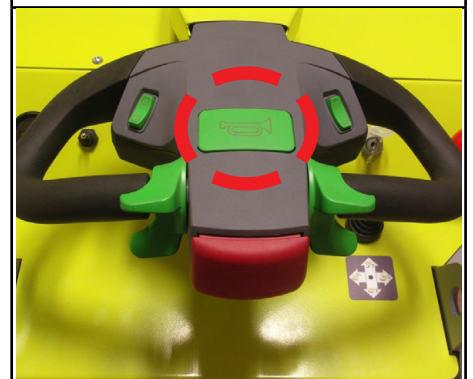

Fig 9: Press the flashing beacon & alert buzzer switch on the tiller control.

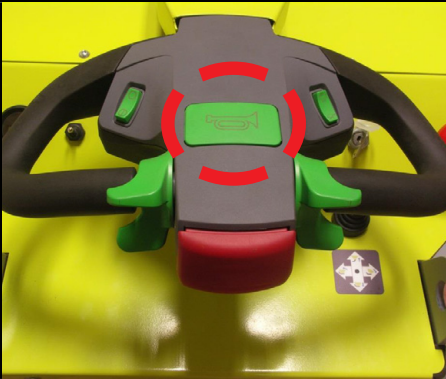

Fig 12: Skip lever. Ensure all 4 functions work correctly.



Fig 15: Remote Control .Up=ON /Down = OFF



Fig 10: Ensure the flash beacon is working correctly.



Fig 13: Emergency Stop. When pressed in stops machine.



Fig 16: Ensure rear facing lights are functioning and free from debris.

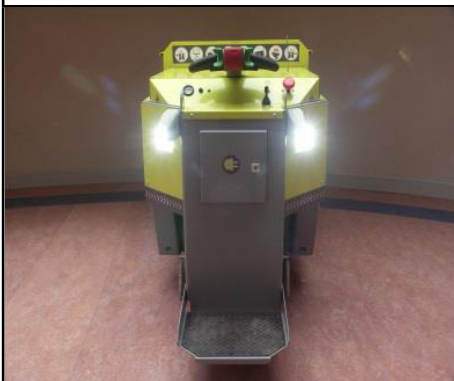

Fig 11: Multi Function Display. Displays battery discharge (BDI), hour meter and error message display.



Fig 14: Light switch. Up=ON / Down = OFF



Fig 17: Ensure front facing lights are functioning and free from debris.



LUBRICATION

Check all 15 grease nipple fittings for proper lubrication, add grease as needed.



CRUSH POINT WARNING! Indicates a hazardous situation which, if not avoided, could result in death or serious injury. Obey all safety messages that follow this symbol to avoid injury or death.

- Ensure the ED is powered off and emergency switch is UP before expecting machine.
- Keep a safe distance back from the machine if another technician is operator the skip function

INSTRUCTIONS

CHECK ALL 15 GREASE NIPPLE FITTINGS FOR PROPER LUBRICATION, ADD GREASE AS NEEDED.

- Remove dust cap from nipple where caps are applied.
- Grease all grease nipple points with suitable grease using a grease gun. The ED range requires just one pump of a standard grease gun.
- Clean surplus grease from nipple with a clean damp cloth and reapply dust cap to nipple.
- **Record Results**

Fig 18: DUST CAP ON

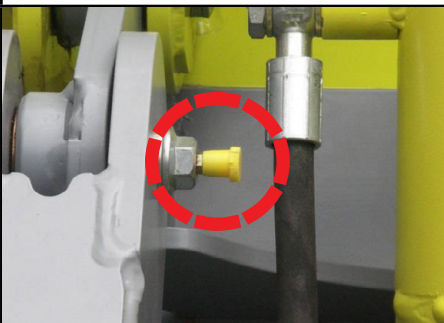

Fig 19: DUST CAP OFF

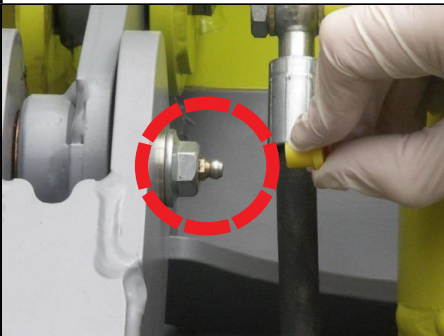

Fig 20: GREASE POINT 1

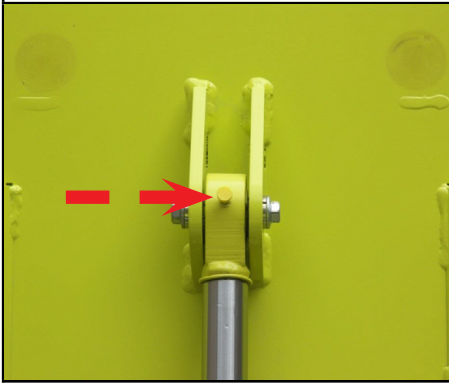

Fig 21: GREASE POINT 2

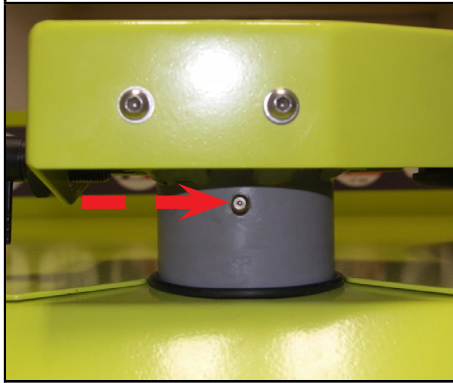

Fig 22: GREASE POINT 3-5

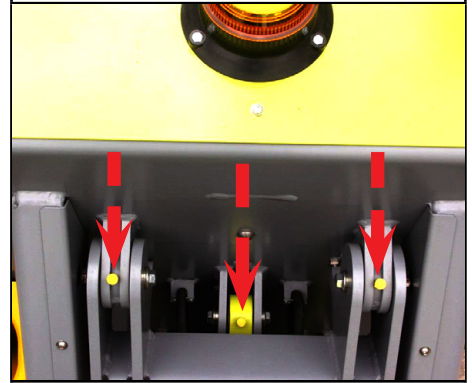

Fig 23: GREASE POINT 6-7

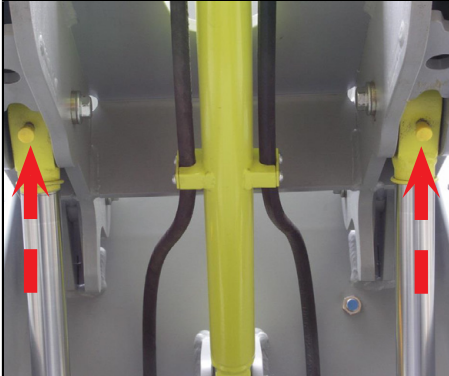

Fig 24: GREASE POINT 8-11

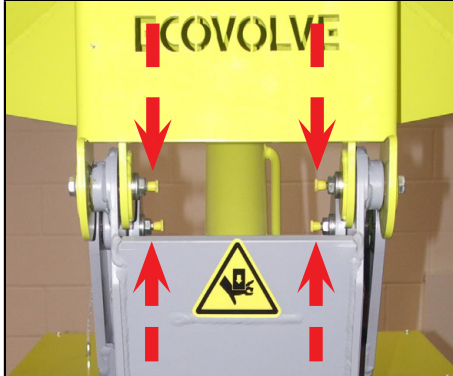

Fig 25: GREASE POINT 12-13

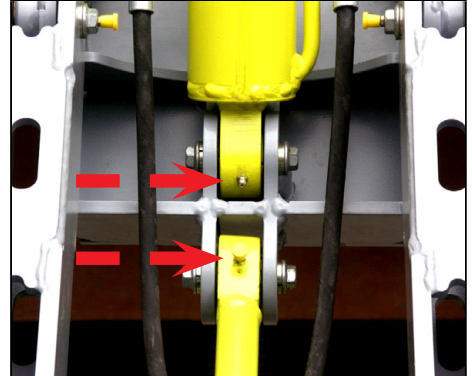
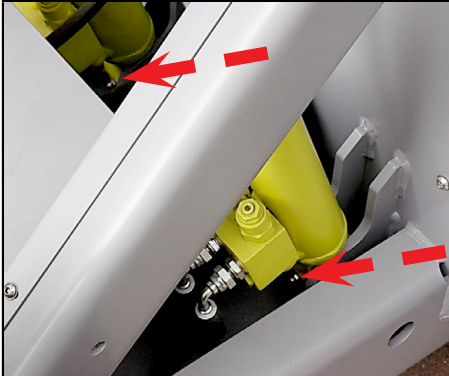





Fig 26: GREASE POINT 14-15







HYDRAULIC SYSTEM	<ol style="list-style-type: none"> 1. Check hydraulic system for leaks. 2. Replace hydraulic oil.
	<p>CAUTION! Indicates a hazardous situation which, if not avoided, could result in moderate or serious injury.</p> <ul style="list-style-type: none"> • Risk of burning from hot hydraulic oil. Allow the oil to cool before running maintenance checks. • Never use your hand to check for an oil leak, hydraulic oil can be hot. Use appropriate hand protection. • Only fill the hydraulic system with new clean recommended hydraulic oil, if the oil is contaminated hydraulic components may become damaged as a result. • Always use the same original type of oil when topping up or changing. • The ED range uses HYD 46 Hydraulic oil. Tank Capacity is 2.8 litres
	<p>CRUSH PARTS WARNING! Indicates a hazardous situation which, if not avoided, could result in death or serious injury. Obey all safety messages that follow this symbol to avoid injury or death.</p>
	<p>HAND PROTECTION REQUIRED! When the instruction for hand protection is required to avoid personal injury.</p>
	<p>PROTECTIVE EYEWEAR REQUIRED! When the instruction for protective eyewear is stated, protective eyewear must always be worn when operating the machine to avoid personal injury.</p>

INSTRUCTIONS

1. CHECK HYDRAULIC SYSTEM FOR LEAKS

- **Risk of burning from hot hydraulic oil.** Allow the oil to cool before running maintenance checks.
- When checking the hydraulic oil level protective gloves and glasses must be worn.
- Raise skip and remove start key from dash.
- Inspect the condition of ALL hydraulic hoses and check for leaks at ALL connection points and ram seals.
- Visually examine all hydraulic components to look for oil leaks.
- If leak is present, do not use and replace components.
- **Record Results**

HYDRAULIC SYSTEM	2. Replace hydraulic oil.
	<p>CAUTION! Indicates a hazardous situation which, if not avoided, could result in moderate or serious injury.</p> <ul style="list-style-type: none"> • Risk of burning from hot hydraulic oil. Allow the oil to cool before running maintenance checks. • Never use your hand to check for an oil leak, hydraulic oil can be hot. Use appropriate hand protection. • Only fill the hydraulic system with new clean recommended hydraulic oil, if the oil is contaminated hydraulic components may become damaged as a result. • Always use the same original type of oil when topping up or changing. • The ED range uses HYD 46 hydraulic oil. Tank capacity is 2.8 litres
	<p>CRUSH PARTS WARNING! Indicates a hazardous situation which, if not avoided, could result in death or serious injury. Obey all safety messages that follow this symbol to avoid injury or death.</p>
	<p>HAND PROTECTION REQUIRED! When the instruction for hand protection is required to avoid personal injury.</p>
	<p>PROTECTIVE EYEWEAR REQUIRED! When the instruction for protective eyewear is stated, protective eyewear must always be worn when operating the machine to avoid personal injury.</p>

INSTRUCTIONS

2. REPLACE HYDRAULIC OIL

- When replacing the hydraulic oil, protective gloves and glasses must be worn.
- Raise skip and remove start key from dash.
- Remove bung from bottom of tank with a 6mm allen key. Retighten after drainage to 22nm.
- Fill with HYD 46 hydraulic oil to the full level on the dipstick.
- **Record Results**

Fig 27: Raise skip to get access to tank. Take all precautions to avoid injury!

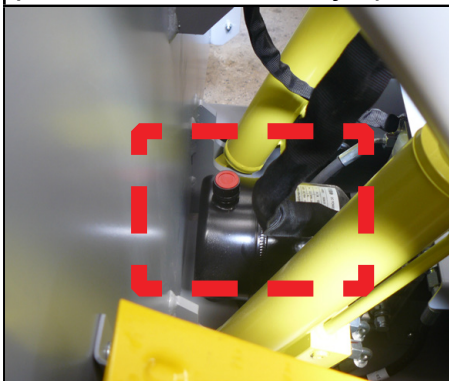
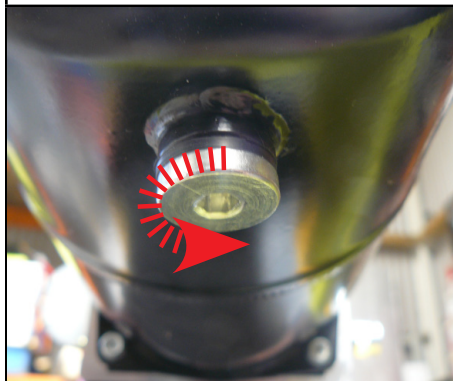



Fig 28: Remove bung with 6mm allen key and drain oil.





REAR DRIVE UNIT	<ol style="list-style-type: none"> 1. Inspect for leaks, defects or unusual noise in the rear drive unit. 2. Grease gears and check for wear. 3. Check oil level.
	<p>After the first 150 working hours of use, the rear drive unit requires its first oil change.</p> <p>Following this service, check the oil level every 500 working hours and change the oil as per regular service intervals which is 2000 working hours.</p>
	<p>CAUTION! Indicates a hazardous situation which, if not avoided, could result in moderate or serious injury.</p>

INSTRUCTIONS

1. INSPECT FOR LEAKS, DEFECTS OR UNUSUAL NOISE IN DRIVE SYSTEM

- Examine all of the rear drive unit for leaks, defects and unusual noise.
- If leak or defect is present, have a competent technician examine and take correct action.
- **Record Results**

REAR DRIVE UNIT	2. Grease gears and check for wear.
	<p>After the first 150 working hours of use, the rear drive unit requires its first oil change.</p> <p>Following this service, check the oil level every 500 working hours and change the oil as per regular service intervals which is 2000 working hours.</p>
	<p>CAUTION! Indicates a hazardous situation which, if not avoided, could result in moderate or serious injury.</p>



INSTRUCTIONS

2. GREASE GEARS AND CHECK FOR WEAR

- Securely park the ED and take all safety precautions.
- Remove side cover of the rear drive unit.
- Grease as needed. Do not overgrease.
- **Record Results**

Fig 29: Remove side cover to grease rear drive unit gears.



REAR DRIVE UNIT	3. Check oil level of rear drive unit.
	<p>After the first 150 working hours of use, the rear drive unit requires its first oil change.</p> <p>Following this service, check the oil level every 500 working hours and change the oil as per regular service intervals which is 2000 working hours.</p>
	<p>CAUTION! Indicates a hazardous situation which, if not avoided, could result in moderate or serious injury.</p>

INSTRUCTIONS

3. CHECK OIL LEVEL OF REAR DRIVE UNIT

- Securely park the ED and take all safety precautions.
- On the bottom of the rear drive unit, check oil level through viewing window.
- If low top up as necessary with **BP ENERGEAR HYPO 85W-140 Oil x 5 Litres**
- **Record Results**

BRAKING SYSTEM	<ol style="list-style-type: none"> 1. Inspect brake performance and adjust as needed. 2. Check for brake wheel wear. 3. Add copper grease to braking system.
	<p>CAUTION! Indicates a hazardous situation which, if not avoided, could result in moderate or serious injury.</p>

INSTRUCTIONS

INSPECT BRAKE PERFORMANCE AND ADJUST AS NEEDED

- To adjust brakes, jack up the ED and secure it on adequate capacity jack stands.
- Remove the adjusting hole cover from the adjusting slot on the bottom of the break backing plate.
- With a flat head screw driver rotate the star wheel of the adjuster to expand the brake shoe assembly.
- Adjust the brake shoes until the pressure of the lining against the drum makes the wheel difficult to turn.
- Then rotate the star wheel adjuster in the opposite direction until the wheel turns freely with a slight lining drag, replace the adjusting hole cover and lower the wheel to the ground.
- Repeat the same procedure for the opposite wheel.
- (2) Examine the entire system for wear.
- **Record Results**

Fig 30:



Fig 31: Adjust brake shoe as needed.



Fig 32: Star wheel

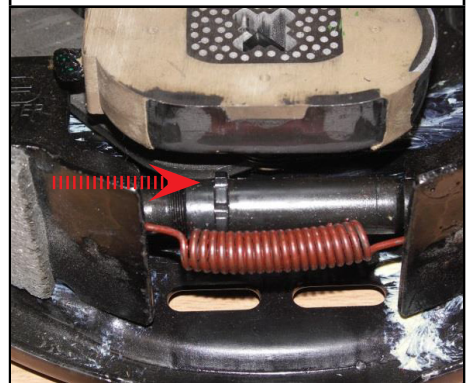

BRAKING
SYSTEM

3. Add copper grease to braking system

**CAUTION!** Indicates a hazardous situation which, if not avoided, could result in moderate or serious injury.

INSTRUCTIONS

ADD COPPER GREASE TO BRAKING SYSTEM

- Make sure all power to the ED is cut off and key removed.
- Remove side panel of the ED.
- Spray a small amount of copper grease into area shown in Fig 34.
- **Record Results**

Fig 33: Cover removed from ED.



Fig 34:



Section 6

2000 WORKING HOUR SERVICE



The following items must be serviced at the specified working hours. Proof must be submitted to Ecovolve that this service has been completed by a competent technician. To do this complete the relevant form and submit it to Ecovolve including all relevant vehicle identification information on www.ecovolve.eu

Failure to do this will reduce your warranty!



2000 WORKING HOUR SERVICE

The following items must be serviced at the specified working hours. Proof must be submitted to Ecovolve that this service has been completed by a competent technician. To do this complete this form and submit it to Ecovolve including all relevant vehicle identification information at www.ecovolve.eu. **Failure to do this will reduce or void your warranty!** The two ED Vehicle Identification Information items required can be found on the rear drive unit and chassis as shown below



SERVICE ITEMS		DATE	COMPLETED BY
Rear Drive Unit	Change rear drive unit oil		
ED Vehicle Identification Information			
		ED Model:	
		ED Serial No & Year:	
		Rear Drive Unit Serial Number:	
		Rear Drive Unit Design:	
		Rear Drive Unit Month And Year of Production:	
		Working Hours Completed at Time of Service:	

REAR DRIVE UNIT OIL CHANGE

REAR DRIVE UNIT	Replace oil.
	<p>After the first 150 working hours of use, the rear drive unit requires its first oil change.</p> <p>Following this service, check the oil level every 500 working hours and change the oil as per regular service intervals which is 2000 working hours.</p>
	<p>CAUTION! Indicates a hazardous situation which, if not avoided, could result in moderate or serious injury.</p> <ul style="list-style-type: none"> • Risk of burning from hot oil. Allow the oil to cool before running maintenance checks. • Relieve the system pressure slowly before starting service on the drive unit • Never use your hand to check for an oil leak, hydraulic oil can be hot. Use appropriate hand protection • Only fill the drive unit system with new clean recommended oil, if the oil is contaminated components may become damaged as a result. • Always use the same original type of oil when topping up or changing. • The ED drive unit uses BP ENERGEAR HYPO 85W-140 Oil x 5 Litres

INSTRUCTIONS

REPLACE REAR DRIVE UNIT OIL

- Before starting any service record the transmission identification number of the rear drive unit for submission to Ecovolve. This is required to maximise your warranty.
- Record the necessary information as shown and submit to Ecovolve at www.ecovolve.eu. A copy of this form is included at the end of this manual.
- The transmission identification number is printed on the well-visible tag placed on one side of the rear drive unit, as shown below.

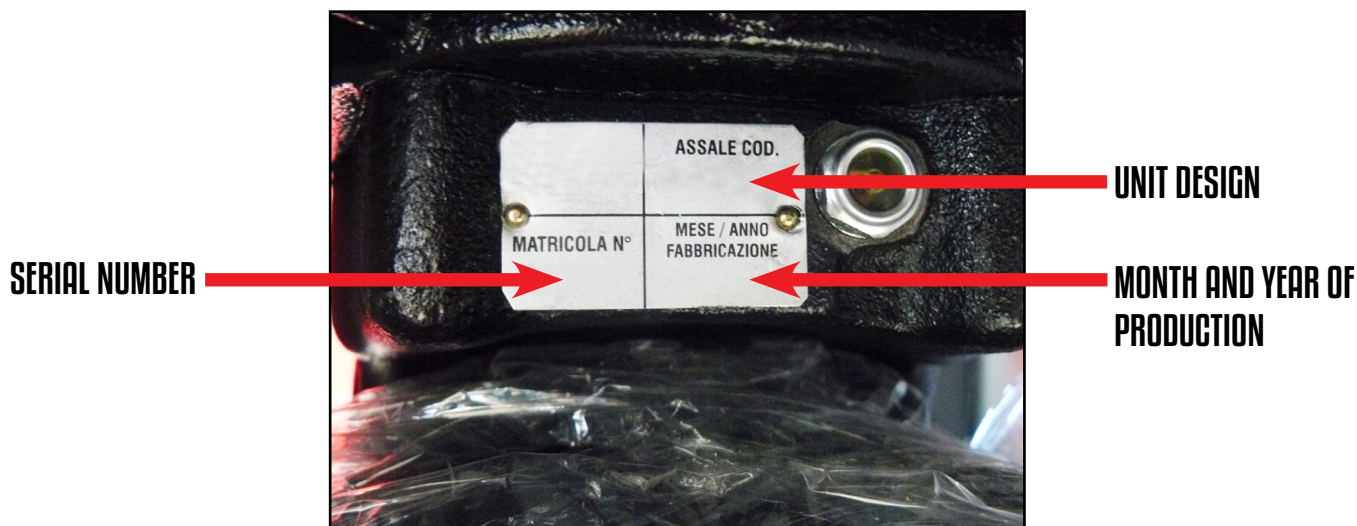

- Lay the vehicle on a flat surface and block the wheels.
- Clean the surface around the oil filling plug and the drain plug.



N.B: When this operation is executed immediately after a long operating time, oil in the unit may be hot; please wear special gloves.

- Put an appropriate container under the drain hole.
- Unscrew the drain plug (ref. 2) by means of an hex wrench 7 mm.
- Convey all the oil into the appropriate container. (Necessary draining time is about 5 min.)
- Clean the plug of the drain hole, apply sealant (ref. 2), screw it and fasten it with a tightening torque of 22 Nm.
- To make topping up easier, use a funnel and small hose. Hose diameter must be 12 mm max.
- During the topping up phase, turn the wheel shaft to prevent air bubbles from coming in.
- Screw the filling plug after having applied sealant (ref. 1) and fasten with a tightening torque of 22 Nm.
- Remove any oil drippings using a dry cloth.
- The oil level must be checked again after a short operating period. Whether necessary top up with same oil till the correct level.
- **Record Result.**

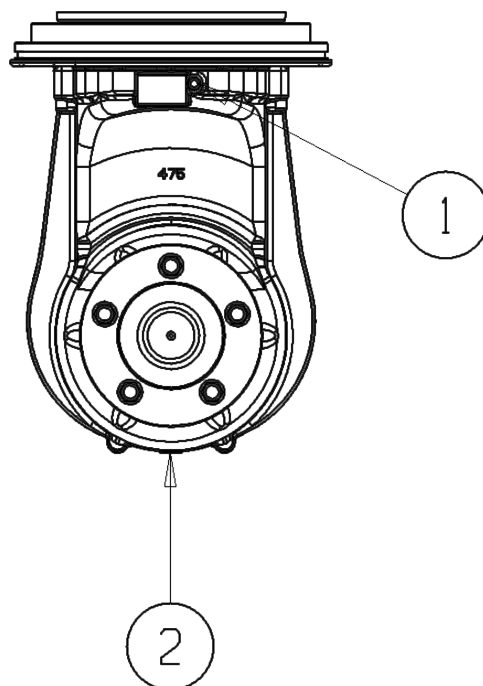

Section 7

SERVICE & INSPECTION FORMS



The following items must be serviced at the specified working hours. Proof must be submitted to Ecovolve that this service has been completed by a competent technician. To do this complete the relevant form and submit it to Ecovolve including all relevant vehicle identification information on www.ecovolve.eu

Failure to do this will reduce your warranty!

DAILY CHECKLIST



WARNING! Failure to follow the daily checklist could result in a hazardous situation which could result in serious injury and damage to the ED.

Always carry out the daily service before operating the electric dumper.

If any item on the daily checklist fails, contact your site supervisor and **DO NOT OPERATE THE DUMPER BEFORE DOING SO.**

DAILY CHECKLIST	DATE	COMPLETED BY
Check the ED for damage and all décor is visible		
Check brakes		
Check tyres & wheels		
Check hydraulic hoses and connections for leaks		
Check the joystick functions		
Check speed switch functions		
Check sounder plinth, horn and beacon		
Check traction paddles		
Check body protection switch		
Check the DBI indicator for errors		
Check all lights		
Check E-Stop button		
Check operators platform & safety rails functions		
Check that all grease nipples are adequately greased		
Check the condition of the charging cables		
Notes:		

50 WORKING HOUR INSPECTION

The following items must be serviced at the specified working hours. The work must be completed by a competent technician.

Failure to do this will reduce or void your warranty! The two ED Vehicle Identification Information items required can be found on the rear drive unit and chassis as shown below.

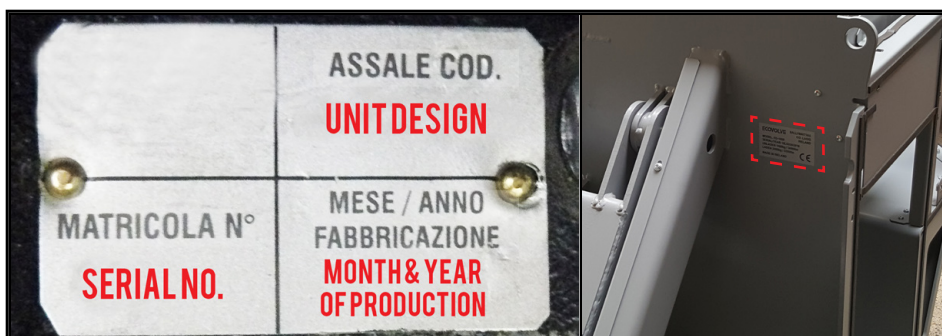

SERVICE ITEMS		DATE	COMPLETED BY
Chassis And Truck Frame	Check all safety symbols and décor is clearly visible		
	Check operator safety rails and platform		
	Check all fixings		
Wheels	Check wheel nuts are tight		
	Check wheel bearings		
Steering & Dashboard	Check all steering functions & switches:		
	-Traction Paddles		
	-Speed Switch		
	-Body protection switch		
	-Horn switch		
	-Safety buzzer		
	-Multi function display		
	-Skip lever functions		
	-Emergency stop button		
	-Lighting switches		
-Remote control (if applicable)			

50 WORKING HOUR INSPECTION CONTD.

SERVICE ITEMS		DATE	COMPLETED BY
Steering & Dashboard Contd.	-Light display		
	-Check all sensors		
	-Test drive machine		
Lubrication	Check all 15 grease nipple fittings for proper lubrication, add grease as needed		
Hydraulic System	Check hydraulic system for leaks		
	Check hydraulic rams		
	Check oil level		
	Check hydraulic performance		
Rear Drive Unit	Check oil level		
Braking System	Check brake performance		
Electric Charging	Check charging system and cables		
Safety Booklet	Check safety booklet is in a useable condition.		
ED Vehicle Identification Information			
		ED Model:	
		ED Serial Number & Year:	
		Rear Drive Unit Serial Number:	
		Rear Drive Unit Design:	
		Rear Drive unit Month And Year of Production:	
		Working Hours Completed at Time of Service:	
Notes:			

150 WORKING HOUR SERVICE (REAR DRIVE UNIT)

The following items must be serviced at the specified working hours. Proof must be submitted to Ecovolve that this service has been completed by a competent technician. To do this complete this form and submit it to Ecovolve including all relevant vehicle identification information at www.ecovolve.eu.

Failure to do this will reduce or void your warranty! The two ED Vehicle Identification Information items required can be found on the rear drive unit and chassis as shown below.

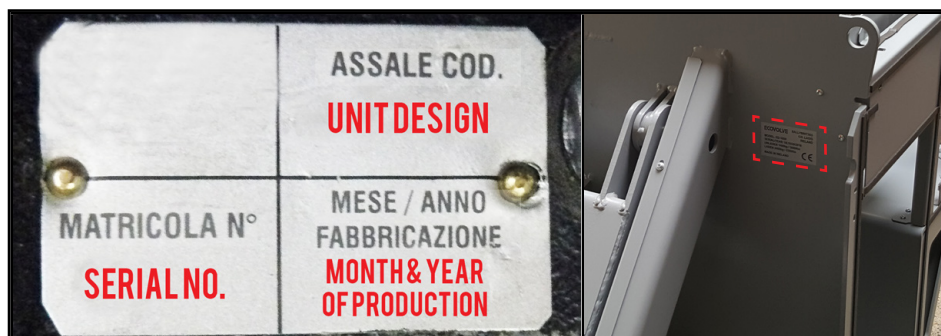

SERVICE ITEMS	DATE	COMPLETED BY
Rear drive unit oil change completed at or before the first 150 working hours		
Required Oil: BP ENERGEAR HYPO 85W-140 Oil x 5 Litres		

ED Vehicle Identification Information

ED Model:	
ED Serial Number & Year:	
Rear Drive Unit Serial Number:	
Rear Drive Unit Number:	
Rear Drive Unit Month And Year of Production:	
Working Hours Completed at Time of Service:	

Notes:

500 WORKING HOUR SERVICE

The following items must be serviced at the specified working hours. Proof must be submitted to Ecovolve that this service has been completed by a competent technician. To do this complete this form and submit it to Ecovolve including all relevant vehicle identification information at www.ecovolve.eu. **Failure to do this will reduce or void your warranty! The two ED Vehicle Identification Information items required can be found on the rear drive unit and chassis as shown below.**



SERVICE ITEMS		DATE	COMPLETED BY
Chassis and Truck Frame	Inspect for any damage of load bearing parts		
	Inspect all rams and joints		
Wheels	Inspect wheels for wear and damage		
	Check wheel tightness		
Steering & Dashboard	Check for any wear or damage to the edges of the skip		
Lubrication	Check all 15 grease nipple fittings for proper lubrication, add grease as needed		
Hydraulic System	Check systems for leaks		
	Change hydraulic system oil		
Rear Drive Unit	Inspect for leaks and unusual noise		
	Grease gears and check for wear		
	Check oil level		
Braking System	Inspect brake performance and adjust as needed		
	Check for brake wheel wear		
	Spray copper grease in braking system		
ED Vehicle Identification Information			
ED Model:			
ED Serial No & Year:			
Rear Drive Unit Serial Number:			
Rear Drive Unit Design:			
Rear Drive Unit Month And Year of Production:			
Working Hours Completed at Time of Service:			

2000 WORKING HOUR SERVICE

The following items must be serviced at the specified working hours. Proof must be submitted to Ecovolve that this service has been completed by a competent technician. To do this complete this form and submit it to Ecovolve including all relevant vehicle identification information at www.ecovolve.eu. **Failure to do this will reduce or void your warranty!** The two ED Vehicle Identification Information items required can be found on the rear drive unit and chassis as shown below

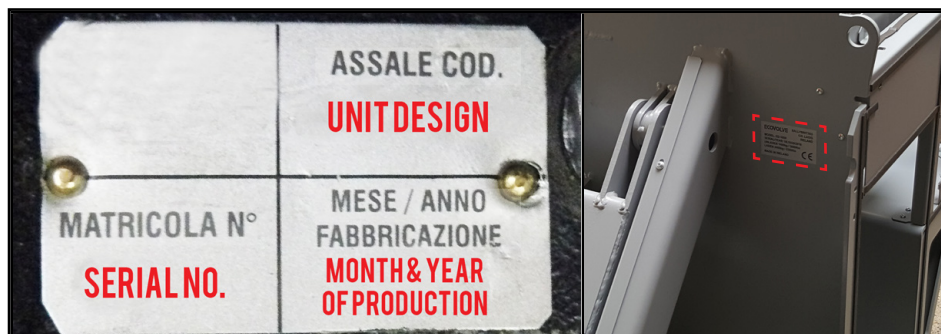

SERVICE ITEMS		DATE	COMPLETED BY
Rear Drive Unit	Change rear drive unit oil		
ED Vehicle Identification Information			
		ED Model:	
		ED Serial No & Year:	
		Rear Drive Unit Serial Number:	
		Rear Drive Unit Design:	
		Rear Drive Unit Month And Year of Production:	
		Working Hours Completed at Time of Service:	

Section 8

TROUBLESHOOTING



In the unlikely event a fault occurs on the ED a fault code will be shown on the BDI display on the dashboard. Use the following codes to troubleshoot. For further assistance contact your local distributor.

Summary of LED display formats

The two LEDs have four different display modes, indicating the type of information they are providing.

DISPLAY	STATUS
Neither LED illuminated	Controller is not powered on; or vehicle has dead battery; or severe damage.
Yellow LED flashing	Controller is operating normally.
Yellow and red LEDs both on solid	Controller is in Flash program mode.
Red LED on solid	Watchdog failure or no software loaded. Cycle KSI to restart, and if necessary load software.
Red LED and yellow LED flashing alternately	Controller has detected a fault. 2-digit code flashed by yellow LED identifies the specific fault; one or two flashes by red LED indicate whether first or second code digit will follow.

TROUBLESHOOTING

The troubleshooting chart, Table 5, provides the following information on all the controller faults:

- fault code
- fault name as displayed on the programmer's LCD
- the effect of the fault
- possible causes of the fault
- fault *set* conditions
- fault *clear* conditions.

Whenever a fault is encountered and no wiring or vehicle fault can be found, shut off KSI and turn it back on to see if the fault clears. If it does not, shut off KSI and remove the 35-pin connector. Check the connector for corrosion or damage, clean it if necessary, and re-insert it.

Table 5 TROUBLESHOOTING CHART

CODE	PROGRAMMER LCD DISPLAY EFFECT OF FAULT	POSSIBLE CAUSE	SET/CLEAR CONDITIONS
12	Controller Overcurrent <i>ShutdownMotor;</i> <i>ShutdownMainContactor;</i> <i>ShutdownEMBrake;</i> <i>ShutdownThrottle;</i> <i>FullBrake;</i> <i>ShutdownPump.</i>	<ol style="list-style-type: none"> External short of phase U,V, or W motor connections. Motor parameters are mis-tuned. Controller defective. Speed encoder noise problems. 	<p><i>Set:</i> Phase current exceeded the current measurement limit.</p> <p><i>Clear:</i> Cycle KSI.</p>
13	Current Sensor Fault <i>ShutdownMotor;</i> <i>ShutdownMainContactor;</i> <i>ShutdownEMBrake;</i> <i>ShutdownThrottle;</i> <i>FullBrake;</i> <i>ShutdownPump.</i>	<ol style="list-style-type: none"> Leakage to vehicle frame from phase U, V, or W (short in motor stator). Controller defective. 	<p><i>Set:</i> Controller current sensors have invalid offset reading.</p> <p><i>Clear:</i> Cycle KSI.</p>
14	Precharge Failed <i>ShutdownMotor;</i> <i>ShutdownMainContactor;</i> <i>ShutdownEMBrake;</i> <i>ShutdownThrottle;</i> <i>FullBrake;</i> <i>ShutdownPump.</i>	<ol style="list-style-type: none"> External load on capacitor bank (B+ connection terminal) that prevents the capacitor bank from charging. See Monitor menu » Battery: Capacitor Voltage. 	<p><i>Set:</i> Precharge failed to charge the capacitor bank to the KSI voltage.</p> <p><i>Clear:</i> Cycle Interlock input or use VCL function <i>Precharge()</i>.</p>
15	Controller Severe Undertemp <i>ShutdownMotor;</i> <i>ShutdownMainContactor;</i> <i>ShutdownEMBrake;</i> <i>ShutdownThrottle;</i> <i>FullBrake;</i> <i>ShutdownPump.</i>	<ol style="list-style-type: none"> See Monitor menu » Controller: Temperature. Controller is operating in an extreme environment. 	<p><i>Set:</i> Heatsink temperature below -40°C.</p> <p><i>Clear:</i> Bring heatsink temperature above -40°C, and cycle interlock or KSI.</p>
16	Controller Severe Overtemp <i>ShutdownMotor;</i> <i>ShutdownMainContactor;</i> <i>ShutdownEMBrake;</i> <i>ShutdownThrottle;</i> <i>FullBrake;</i> <i>ShutdownPump.</i>	<ol style="list-style-type: none"> See Monitor menu » Controller: Temperature. Controller is operating in an extreme environment. Excessive load on vehicle. Improper mounting of controller. 	<p><i>Set:</i> Heatsink temperature above +95°C.</p> <p><i>Clear:</i> Bring heatsink temperature below +95°C, and cycle interlock or KSI.</p>
17	Severe Undervoltage <i>Reduced drive torque.</i>	<ol style="list-style-type: none"> Battery Menu parameters are misadjusted. Non-controller system drain on battery. Battery resistance too high. Battery disconnected while driving. See Monitor menu » Battery: Capacitor Voltage. Blown B+ fuse or main contactor did not close. 	<p><i>Set:</i> Capacitor bank voltage dropped below the Severe Undervoltage limit (see page 55) with FET bridge enabled.</p> <p><i>Clear:</i> Bring capacitor voltage above Severe Undervoltage limit.</p>

Table 5 TROUBLESHOOTING CHART, continued

CODE	PROGRAMMER LCD DISPLAY EFFECT OF FAULT	POSSIBLE CAUSE	SET/CLEAR CONDITIONS
18	Severe Overvoltage <i>ShutdownMotor;</i> <i>ShutdownMainContactor;</i> <i>ShutdownEMBrake;</i> <i>ShutdownThrottle;</i> <i>FullBrake;</i> <i>ShutdownPump.</i>	<ol style="list-style-type: none"> 1. See Monitor menu » Battery: Capacitor Voltage. 2. Battery menu parameters are misadjusted. 3. Battery resistance too high for given regen current. 4. Battery disconnected while regen braking. 	<p><i>Set:</i> Capacitor bank voltage exceeded the Severe Overvoltage limit (see page 55) with FET bridge enabled.</p> <p><i>Clear:</i> Bring capacitor voltage below Severe Overvoltage limit, and then cycle KSI.</p>
22	Controller Overtemp Cutback <i>Reduced drive and brake torque.</i>	<ol style="list-style-type: none"> 1. See Monitor menu » Controller: Temperature. 2. Controller is performance-limited at this temperature. 3. Controller is operating in an extreme environment. 4. Excessive load on vehicle. 5. Improper mounting of controller. 	<p><i>Set:</i> Heatsink temperature exceeded 85°C.</p> <p><i>Clear:</i> Bring heatsink temperature below 85°C.</p>
23	Undervoltage Cutback <i>Reduced drive torque.</i>	<ol style="list-style-type: none"> 1. Normal operation. Fault shows that the batteries need recharging. Controller is performance limited at this voltage. 2. Battery parameters are misadjusted. 3. Non-controller system drain on battery. 4. Battery resistance too high. 5. Battery disconnected while driving. 6. See Monitor menu » Battery: Capacitor Voltage. 7. Blown B+ fuse or main contactor did not close. 	<p><i>Set:</i> Capacitor bank voltage dropped below the Undervoltage limit (see page 55) with the FET bridge enabled.</p> <p><i>Clear:</i> Bring capacitor voltage above the Undervoltage limit.</p>
24	Overvoltage Cutback <i>Reduced brake torque.</i>	<ol style="list-style-type: none"> 1. Normal operation. Fault shows that regen braking currents elevated the battery voltage during regen braking. Controller is performance limited at this voltage. 2. Battery parameters are misadjusted. 3. Battery resistance too high for given regen current. 4. Battery disconnected while regen braking. 5. See Monitor menu » Battery: Capacitor Voltage. 	<p><i>Set:</i> Capacitor bank voltage exceeded the Overvoltage limit (see page 55) with the FET bridge enabled.</p> <p><i>Clear:</i> Bring capacitor voltage below the Overvoltage limit.</p>
25	+5V Supply Failure <i>None, unless a fault action is programmed in VCL.</i>	<ol style="list-style-type: none"> 1. External load impedance on the +5V supply (pin 26) is too low. 2. See Monitor menu » outputs: 5 Volts and Ext Supply Current. 	<p><i>Set:</i> +5V supply (pin 26) outside the +5V±10% range.</p> <p><i>Clear:</i> Bring voltage within range.</p>
26	Digital Out 6 Overcurrent <i>Digital Output 6 driver will not turn on.</i>	<ol style="list-style-type: none"> 1. External load impedance on Digital Output 6 driver (pin 19) is too low. 	<p><i>Set:</i> Digital Output 6 (pin 19) current exceeded 15 mA.</p> <p><i>Clear:</i> Remedy the overcurrent cause and use the VCL function <i>Set_DigOut()</i> to turn the driver on again.</p>

CODE	PROGRAMMER LCD DISPLAY EFFECT OF FAULT	POSSIBLE CAUSE	SET/CLEAR CONDITIONS
27	Digital Out 7 Overcurrent <i>Digital Output 7 driver will not turn on.</i>	1. External load impedance on Digital Output 7 driver (pin 20) is too low.	<i>Set:</i> Digital Output 7 (pin 20) current exceeded 15 mA. <i>Clear:</i> Remedy the overcurrent cause and use the VCL function <i>Set_DigOut()</i> to turn the driver on again.
28	Motor Temp Hot Cutback <i>Reduced drive torque.</i>	1. Motor temperature is at or above the programmed Temperature Hot setting, and the requested current is being cut back. 2. Motor Temperature Control Menu parameters are mis-tuned. 3. See Monitor menu » Motor: Temperature and » Inputs: Analog2. 4. If the application doesn't use a motor thermistor, Temp Compensation and Temp Cutback should be programmed Off.	<i>Set:</i> Motor temperature is at or above the Temperature Hot parameter setting. <i>Clear:</i> Bring the motor temperature within range.
29	Motor Temp Sensor Fault <i>Max.Speed reduced (LOS, Limited Operating Strategy), and motor temperature cutback disabled.</i>	1. Motor thermistor is not connected properly. 2. If the application doesn't use a motor thermistor, Motor Temp Sensor Enable should be programmed Off. 3. See Monitor menu » Motor: Temperature and » Inputs: Analog2.	<i>Set:</i> Motor thermistor input (pin 8) is at the voltage rail (0 or 10V). <i>Clear:</i> Bring the motor thermistor input voltage within range.
31	Coil1 Driver Open/Short <i>ShutdownDriver1.</i>	1. Open or short on driver load. 2. Dirty connector pins. 3. Bad crimps or faulty wiring.	<i>Set:</i> Driver 1 (pin 6) is either open or shorted. This fault can be set only when Main Enable = Off. <i>Clear:</i> Correct open or short, and cycle driver.
31	Main Open/Short <i>ShutdownMotor; ShutdownMainContactor; ShutdownEMBrake; ShutdownThrottle; FullBrake; ShutdownPump.</i>	1. Open or short on driver load. 2. Dirty connector pins. 3. Bad crimps or faulty wiring.	<i>Set:</i> Main contactor driver (pin 6) is either open or shorted. This fault can be set only when Main Enable = On. <i>Clear:</i> Correct open or short, and cycle driver
32	Coil2 Driver Open/Short <i>ShutdownDriver2.</i>	1. Open or short on driver load. 2. Dirty connector pins. 3. Bad crimps or faulty wiring.	<i>Set:</i> Driver 2 (pin 5) is either open or shorted. This fault can be set only when EM Brake Type = 0. <i>Clear:</i> Correct open or short, and cycle driver.
32	EMBrake Open/Short <i>ShutdownEMBrake; ShutdownThrottle; FullBrake.</i>	1. Open or short on driver load. 2. Dirty connector pins. 3. Bad crimps or faulty wiring.	<i>Set:</i> Electromagnetic brake driver (pin 5) is either open or shorted. This fault can be set only when EM Brake Type >0. <i>Clear:</i> Correct open or short, and cycle driver.
33	Coil3 Driver Open/Short <i>ShutdownDriver3.</i>	1. Open or short on driver load. 2. Dirty connector pins. 3. Bad crimps or faulty wiring.	<i>Set:</i> Driver 3 (pin 4) is either open or shorted. <i>Clear:</i> Correct open or short, and cycle driver.
34	Coil4 Driver Open/Short <i>ShutdownDriver4.</i>	1. Open or short on driver load. 2. Dirty connector pins. 3. Bad crimps or faulty wiring.	<i>Set:</i> Driver 4 (pin 3) is either open or shorted. <i>Clear:</i> Correct open or short, and cycle driver.

Table 5 TROUBLESHOOTING CHART, continued

CODE	PROGRAMMER LCD DISPLAY EFFECT OF FAULT	POSSIBLE CAUSE	SET/CLEAR CONDITIONS
35	PD Open/Short <i>ShutdownPD.</i>	<ol style="list-style-type: none"> 1. Open or short on driver load. 2. Dirty connector pins. 3. Bad crimps or faulty wiring. 	<p><i>Set:</i> Proportional driver (pin 2) is either open or shorted.</p> <p><i>Clear:</i> Correct open or short, and cycle driver.</p>
36	Encoder Fault <i>ShutdownEMBrake;</i> <i>ShutdownThrottle.</i>	<ol style="list-style-type: none"> 1. Motor encoder failure. 2. Bad crimps or faulty wiring. 3. See Monitor menu » Motor: Motor RPM. 	<p><i>Set:</i> Motor encoder phase failure detected.</p> <p><i>Clear:</i> Cycle KSI.</p>
37	Motor Open <i>ShutdownMotor;</i> <i>ShutdownMainContactor;</i> <i>ShutdownEMBrake;</i> <i>ShutdownThrottle;</i> <i>FullBrake;</i> <i>ShutdownPump.</i>	<ol style="list-style-type: none"> 1. Motor phase is open. 2. Bad crimps or faulty wiring. 	<p><i>Set:</i> Motor phase U, V, or W detected open.</p> <p><i>Clear:</i> Cycle KSI.</p>
38	Main Contactor Welded <i>ShutdownMotor;</i> <i>ShutdownMainContactor;</i> <i>ShutdownEMBrake;</i> <i>ShutdownThrottle;</i> <i>FullBrake;</i> <i>ShutdownPump.</i>	<ol style="list-style-type: none"> 1. Main contactor tips are welded closed. 2. Motor phase U or V is disconnected or open. 3. An alternate voltage path (such as an external precharge resistor) is providing a current to the capacitor bank (B+ connection terminal). 	<p><i>Set:</i> Just prior to the main contactor closing, the capacitor bank voltage (B+ connection terminal) was loaded for a short time and the voltage did not discharge.</p> <p><i>Clear:</i> Cycle KSI</p>
39	Main Contactor Did Not Close <i>ShutdownMotor;</i> <i>ShutdownMainContactor;</i> <i>ShutdownEMBrake;</i> <i>ShutdownThrottle;</i> <i>FullBrake;</i> <i>ShutdownPump.</i>	<ol style="list-style-type: none"> 1. Main contactor did not close. 2. Main contactor tips are oxidized, burned, or not making good contact. 3. External load on capacitor bank (B+ connection terminal) that prevents capacitor bank from charging. 4. Blown B+ fuse. 	<p><i>Set:</i> With the main contactor commanded closed, the capacitor bank voltage (B+ connection terminal) did not charge to B+.</p> <p><i>Clear:</i> Cycle KSI.</p>
41	Throttle Wiper High <i>ShutdownThrottle.</i>	<ol style="list-style-type: none"> 1. See Monitor menu » Inputs: Throttle Pot. 2. Throttle pot wiper voltage too high. 	<p><i>Set:</i> Throttle pot wiper (pin 16) voltage is higher than the high fault threshold (can be changed with the VCL function <i>Setup_Pot_Faults()</i>).</p> <p><i>Clear:</i> Bring throttle pot wiper voltage below the fault threshold.</p>
42	Throttle Wiper Low <i>ShutdownThrottle.</i>	<ol style="list-style-type: none"> 1. See Monitor menu » Inputs: Throttle Pot. 2. Throttle pot wiper voltage too low. 	<p><i>Set:</i> Throttle pot wiper (pin 16) voltage is lower than the low fault threshold (can be changed with the VCL function <i>Setup_Pot_Faults()</i>).</p> <p><i>Clear:</i> Bring throttle pot wiper voltage above the fault threshold.</p>
43	Pot2 Wiper High <i>FullBrake.</i>	<ol style="list-style-type: none"> 1. See Monitor menu » Inputs: Pot2 Raw. 2. Pot2 wiper voltage too high. 	<p><i>Set:</i> Pot2 wiper (pin 17) voltage is higher than the high fault threshold (can be changed with the VCL function <i>Setup_Pot_Faults()</i>).</p> <p><i>Clear:</i> Bring Pot2 wiper voltage below the fault threshold.</p>

Table 5 TROUBLESHOOTING CHART, continued

CODE	PROGRAMMER LCD DISPLAY EFFECT OF FAULT	POSSIBLE CAUSE	SET/CLEAR CONDITIONS
44	Pot2 Wiper Low <i>FullBrake.</i>	<ol style="list-style-type: none"> See Monitor menu » Inputs: Pot2 Raw. Pot2 wiper voltage too low. 	<p><i>Set:</i> Pot2 wiper (pin 17) voltage is lower than the low fault threshold (can be changed with the VCL function <i>Setup_Pot_Faults()</i>).</p> <p><i>Clear:</i> Bring Pot2 wiper voltage above the fault threshold.</p>
45	Pot Low Overcurrent <i>ShutdownThrottle;</i> <i>FullBrake.</i>	<ol style="list-style-type: none"> See Monitor menu » Outputs: Pot Low. Combined pot resistance connected to pot low is too low. 	<p><i>Set:</i> Pot low (pin 18) current exceeds 10mA.</p> <p><i>Clear:</i> Clear pot low overcurrent condition and cycle KSI.</p>
46	EEPROM Failure <i>ShutdownMotor;</i> <i>ShutdownMainContactor;</i> <i>ShutdownEMBrake;</i> <i>ShutdownThrottle;</i> <i>ShutdownInterlock;</i> <i>ShutdownDriver1;</i> <i>ShutdownDriver2;</i> <i>ShutdownDriver3;</i> <i>ShutdownDriver4;</i> <i>ShutdownPD;</i> <i>FullBrake;</i> <i>ShutdownPump.</i>	<ol style="list-style-type: none"> Failure to write to EEPROM memory. This can be caused by EEPROM memory writes initiated by VCL, by the CAN bus, by adjusting parameters with the programmer, or by loading new software into the controller. 	<p><i>Set:</i> Controller operating system tried to write to EEPROM memory and failed.</p> <p><i>Clear:</i> Download the correct software (OS) and matching parameter default settings into the controller and cycle KSI.</p>
47	HPD/Sequencing Fault <i>ShutdownThrottle.</i>	<ol style="list-style-type: none"> KSI, interlock, direction, and throttle inputs applied in incorrect sequence. Faulty wiring, crimps, or switches at KSI, interlock, direction, or throttle inputs. See Monitor menu » Inputs. 	<p><i>Set:</i> HPD (High Pedal Disable) or sequencing fault caused by incorrect sequence of KSI, interlock, direction, and throttle inputs.</p> <p><i>Clear:</i> Reapply inputs in correct sequence.</p>
47	Emer Rev HPD <i>ShutdownThrottle;</i> <i>ShutdownEMBrake.</i>	<ol style="list-style-type: none"> Emergency Reverse operation has concluded, but the throttle, forward and reverse inputs, and interlock have not been returned to neutral. 	<p><i>Set:</i> At the conclusion of Emergency Reverse, the fault was set because various inputs were not returned to neutral.</p> <p><i>Clear:</i> If EMR_Interlock = On, clear the interlock, throttle, and direction inputs. If EMR_Interlock = Off, clear the throttle and direction inputs.</p>
49	Parameter Change Fault <i>ShutdownMotor;</i> <i>ShutdownMainContactor;</i> <i>ShutdownEMBrake;</i> <i>ShutdownThrottle;</i> <i>FullBrake;</i> <i>ShutdownPump.</i>	<ol style="list-style-type: none"> This is a safety fault caused by a change in certain parameter settings so that the vehicle will not operate until KSI is cycled. For example, if a user changes the Throttle Type this fault will appear and require cycling KSI before the vehicle can operate. 	<p><i>Set:</i> Adjustment of a parameter setting that requires cycling of KSI.</p> <p><i>Clear:</i> Cycle KSI.</p>
51–67	OEM Faults (<i>See OEM documentation.</i>)	<ol style="list-style-type: none"> These faults can be defined by the OEM and are implemented in the application-specific VCL code. See OEM documentation. 	<p><i>Set:</i> See OEM documentation.</p> <p><i>Clear:</i> See OEM documentation.</p>

Table 5 TROUBLESHOOTING CHART, continued

CODE	PROGRAMMER LCD DISPLAY EFFECT OF FAULT	POSSIBLE CAUSE	SET/CLEAR CONDITIONS
68	VCL Run Time Error <i>ShutdownMotor;</i> <i>ShutdownMainContactor;</i> <i>ShutdownEMBrake;</i> <i>ShutdownThrottle;</i> <i>ShutdownInterlock;</i> <i>ShutdownDriver1;</i> <i>ShutdownDriver2;</i> <i>ShutdownDriver3;</i> <i>ShutdownDriver4;</i> <i>ShutdownPD;</i> <i>FullBrake;</i> <i>ShutdownPump.</i>	<ol style="list-style-type: none"> VCL code encountered a runtime VCL error. See Monitor menu » Controller: VCL Error Module and VCL Error. This error can then be compared to the runtime VCL module ID and error code definitions found in the specific OS system information file. 	<p><i>Set:</i> Runtime VCL code error condition.</p> <p><i>Clear:</i> Edit VCL application software to fix this error condition; flash the new compiled software and matching parameter defaults; cycle KSI.</p>
69	External Supply Out of Range <i>None, unless a fault action is programmed in VCL.</i>	<ol style="list-style-type: none"> External load on the 5V and 12V supplies draws either too much or too little current. Fault Checking Menu parameters Ext Supply Max and Ext Supply Min are mis-tuned. See Monitor menu » Outputs: Ext Supply Current. 	<p><i>Set:</i> The external supply current (combined current used by the 5V supply [pin 26] and 12V supply [pin 25]) is either greater than the upper current threshold or lower than the lower current threshold. The two thresholds are defined by the External Supply Max and External Supply Min parameter settings (page 52).</p> <p><i>Clear:</i> Bring the external supply current within range.</p>
71	OS General <i>ShutdownMotor;</i> <i>ShutdownMainContactor;</i> <i>ShutdownEMBrake;</i> <i>ShutdownThrottle;</i> <i>ShutdownInterlock;</i> <i>ShutdownDriver1;</i> <i>ShutdownDriver2;</i> <i>ShutdownDriver3;</i> <i>ShutdownDriver4;</i> <i>ShutdownPD;</i> <i>FullBrake;</i> <i>ShutdownPump.</i>	<ol style="list-style-type: none"> Internal controller fault. 	<p><i>Set:</i> Internal controller fault detected.</p> <p><i>Clear:</i> Cycle KSI.</p>
72	PDO Timeout <i>ShutdownInterlock;</i> <i>CAN NMT State set to Pre-operational.</i>	<ol style="list-style-type: none"> Time between CAN PDO messages received exceeded the PDO Timeout Period. 	<p><i>Set:</i> Time between CAN PDO messages received exceeded the PDO Timeout Period.</p> <p><i>Clear:</i> Cycle KSI or receive CAN NMT message.</p>
73	Stall Detected <i>ShutdownEMBrake;</i> <i>ShutdownThrottle;</i> <i>Control Mode changed to LOS (Limited Operating Strategy).</i>	<ol style="list-style-type: none"> Stalled motor. Motor encoder failure. Bad crimps or faulty wiring. Problems with power supply for the motor encoder. See Monitor menu » Motor: Motor RPM. 	<p><i>Set:</i> No motor encoder movement detected.</p> <p><i>Clear:</i> Either cycle KSI, or detect valid motor encoder signals while operating in LOS mode and return Throttle Command = 0 and Motor RPM = 0.</p>
74	Fault On Other Traction Controller	Dual Drive fault: see Dual Drive manual.	
75	Dual Severe Fault	Dual Drive fault: see Dual Drive manual.	

Table 5 TROUBLESHOOTING CHART, continued

CODE	PROGRAMMER LCD DISPLAY EFFECT OF FAULT	POSSIBLE CAUSE	SET/CLEAR CONDITIONS
87	Motor Characterization Fault <i>ShutdownMotor;</i> <i>ShutdownMainContactor;</i> <i>ShutdownEMBrake;</i> <i>ShutdownThrottle;</i> <i>FullBrake;</i> <i>ShutdownPump.</i>	1. Motor characterization failed during characterization process. See Monitor menu » Controller: Motor Characterization Error for cause: 0=none 1=encoder signal seen, but step size not determined; set Encoder Step Size manually 2=motor temp sensor fault 3=motor temp hot cutback fault 4= controller overtemp cutback fault 5=controller undertemp cutback fault 6=undervoltage cutback fault 7=severe overvoltage fault 8=encoder signal not seen, or one or both channels missing 9=motor parameters out of characterization range.	<i>Set:</i> Motor characterization failed during the motor characterization process. <i>Clear:</i> Correct fault; cycle KSI.
89	Motor Type Fault <i>ShutdownMotor;</i> <i>ShutdownMainContactor;</i> <i>ShutdownEMBrake;</i> <i>ShutdownThrottle;</i> <i>FullBrake;</i> <i>ShutdownPump.</i>	1. The Motor_Type parameter value is out of range.	<i>Set:</i> Motor_Type parameter is set to an illegal value. <i>Clear:</i> Set Motor_Type to correct value and cycle KSI.
91	VCL/OS Mismatch <i>ShutdownMotor;</i> <i>ShutdownMainContactor;</i> <i>ShutdownEMBrake;</i> <i>ShutdownThrottle;</i> <i>ShutdownInterlock;</i> <i>ShutdownDriver1;</i> <i>ShutdownDriver2;</i> <i>ShutdownDriver3;</i> <i>ShutdownDriver4;</i> <i>ShutdownPD;</i> <i>FullBrake;</i> <i>ShutdownPump.</i>	1. The VCL software in the controller does not match the OS software in the controller.	<i>Set:</i> VCL and OS software do not match; when KSI cycles, a check is made to verify that they match and a fault is issued when they do not. <i>Clear:</i> Download the correct VCL and OS software into the controller.
92	EM Brake Failed to Set <i>ShutdownEMBrake;</i> <i>ShutdownThrottle.</i>	1. Vehicle movement sensed after the EM Brake has been commanded to set. 2. EM Brake will not hold the motor from rotating.	<i>Set:</i> After the EM Brake was commanded to set and time has elapsed to allow the brake to fully engage, vehicle movement has been sensed. <i>Clear:</i> Activate the throttle.
93	Encoder LOS (Limited Operating Strategy) <i>Enter LOS control mode.</i>	1. Limited Operating Strategy (LOS) control mode has been activated, as a result of either an Encoder Fault (Code 36) or a Stall Detect Fault (Code 73). 2. Motor encoder failure. 3. Bad crimps or faulty wiring. 4. Vehicle is stalled.	<i>Set:</i> Encoder Fault (Code 36) or Stall Detect Fault (Code 73) was activated, and Brake or Interlock has been applied to activate LOS control mode, allowing limited motor control. <i>Clear:</i> Cycle KSI or , if LOS mode was activated by the Stall Fault, clear by ensuring encoder senses proper operation, Motor RPM = 0, and Throttle Command = 0.

ECOVOLVE

www.ecovolve.eu
info@ecovolve.eu